



# AUTEXIER

MANUFACTURER OF INDUSTRIAL VALVES

93 Rue Louis Blanc - 02300 CHAUNY - FRANCE  
 Phone: +33 (0)3 23 52 02 86 Fax: +33 (0)3 23 39 52 28  
 Website: www.autexier.fr

Ref. 360 Family : 27

Rev. 18

Date : 27 Jan. 2026

Page 1/1

## BRONZE SAFETY VALVE

Ref. 360.Ø / 360.ØBP / 360TØ

### SERIES :

- 360.Ø : FPM Disc
- 360.ØBP : VMQ Disc (low pressure)
- 360TØ : PTFE Disc
- High-flow valve / speed lift
- Free outlet

For material compatibility, contact us

### CARACTERISTICS :

- PN40 (Nominal Pressure)
- END : BSP Thread
- MATERIAL : BRONZE CC491K

### MAXIMUM CONDITIONS OF USE :

- 360.Ø : 40 bar of -15°C to 200°C
- 360.ØBP : 40 bar of -50°C to 220°C
- 360TØ : 40 bar of -50°C to 225°C

### APPLICATIONS :

- Compressed air
- Non-toxic gases
- Oxygen

### OPTIONS :

- NPT connection
- Flange connection
- Degreased disc

Specific dimensions, contact us

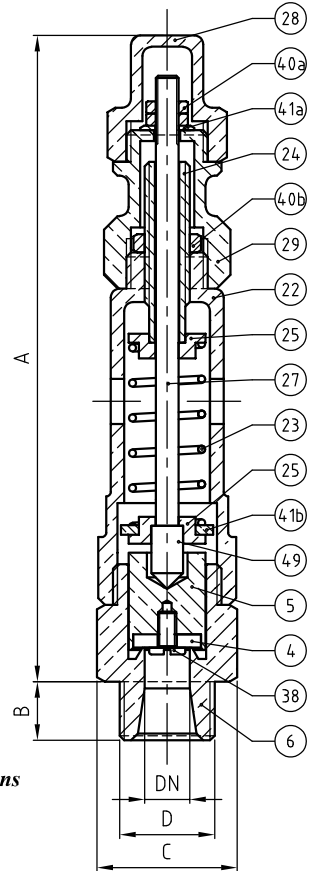

Subject to modifications

NOMENCLATURE			
Rep	Qty	Designation	Material
4	1	DISC	360:FPM / 360BP:VMQ / 360T:PTFE
5	1	DISC HOLDER	BRASS
6	1	SEAT	BRONZE
22	1	LANTERN	BRONZE
23	1	SPRING	STAINLESS STEEL 302
24	1	ADJUSTING SCREW	BRASS
25	2	CARRIER	BRASS
27	1	NEEDLE	BRASS
28	1	CAP	BRONZE
29	1	ADJUSTMENT WHEEL	BRONZE
38	1	SCREW	STAINLESS STEEL A4
40a	2	NUT	BRASS
40b	1	NUT	BRASS
41a	1	WASHER	BRASS
41b	1	WASHER	BRASS
49	1	NOZZLE	BRASS

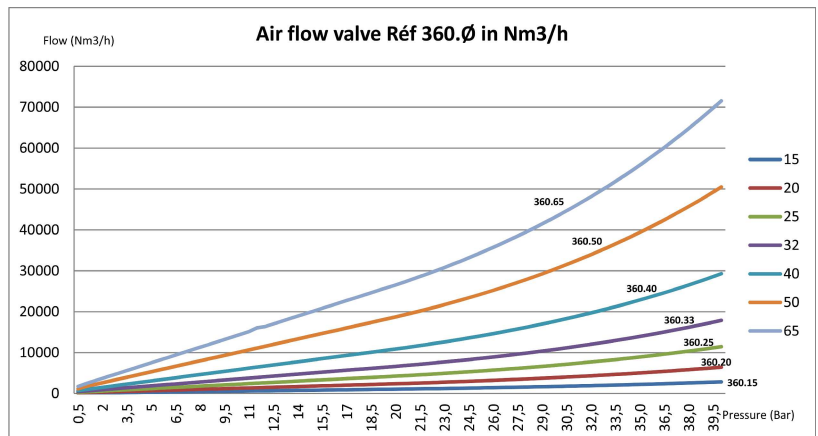

### REFERENCES NORMS :

- Material : NF EN 1982 - NF EN 12163 - NF EN 12164 - NF EN 10272
- Testing & checking : NF EN 12266-1/-2 (bench test)
- Safety devices for protection against excessive pressure : NF EN ISO 4126-7/A1
- Shell design strength : NF EN 12516-3
- Thread : ISO 228-1

Ref. instruction of assembling : 0904DA091E

Ref. instruction of operation : 0904DA095E

**Mounting & assembly guides are available on our website.**

DIMENSIONS							
DN	15	20	25	32	40	50	65
A (mm)	143	169	186	230	288	307	340
B (mm)	13	15	17	18	20	28	32
C (mm)	24	35	41	52	60	78	94
D	G 1/2"	G 3/4"	G 1"	G 1 1/4"	G 1 1/2"	G 2"	G 2 1/2"
Weight (Kg)	0.416	0.703	1.018	1.575	2.750	4.130	6.910
Section (mm²)	78.5	176.7	314.2	490.9	804.2	1385.4	1963.5

These data are for information and can be modified without notice. It is not up to us to appreciate specifications. It is up to the customer to verify the adequacy between the equipment chosen and the real conditions of use.