



AUTEXIER

MANUFACTURER OF INDUSTRIAL VALVES

93 Rue Louis Blanc - 02300 CHAUNY - FRANCE
 Phone : +33 (0)3 23 52 02 86 Fax : +33 (0)3 23 39 52 28
 Website : www.autexier.fr

Ref. AU76 Family : 49

Rev. 02

Date : 11 Feb. 2025

Page 1/1

ALUMINIUM BRONZE 3 WAY BALL VALVE WITH FLANGES

Ref. AU76L65

SERIES :

- AU76
- Three-way L

For material compatibility, contact us

CARACTERISTICS :

- PN30 (Nominal Pressure)
- ENDS : ISO PN16 Flanges
- MATERIAL : ALUMINIUM BRONZE CC333G

MAXIMUM CONDITIONS OF USE :

- 30 bar of -10°C to 200°C

APPLICATIONS :

- Water-based fluids
- Oil & gas
- Sea water

OPTIONS :

- Special drilling
- Lockable handle
- Monel stem and ball
- Fourth way

Specific dimensions, contact us

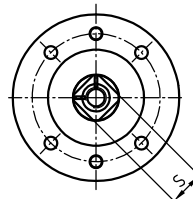
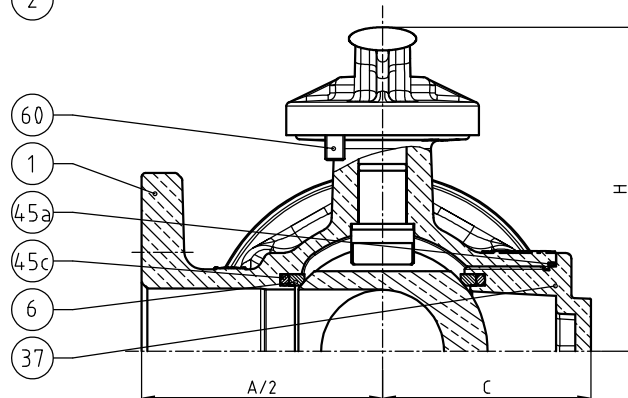
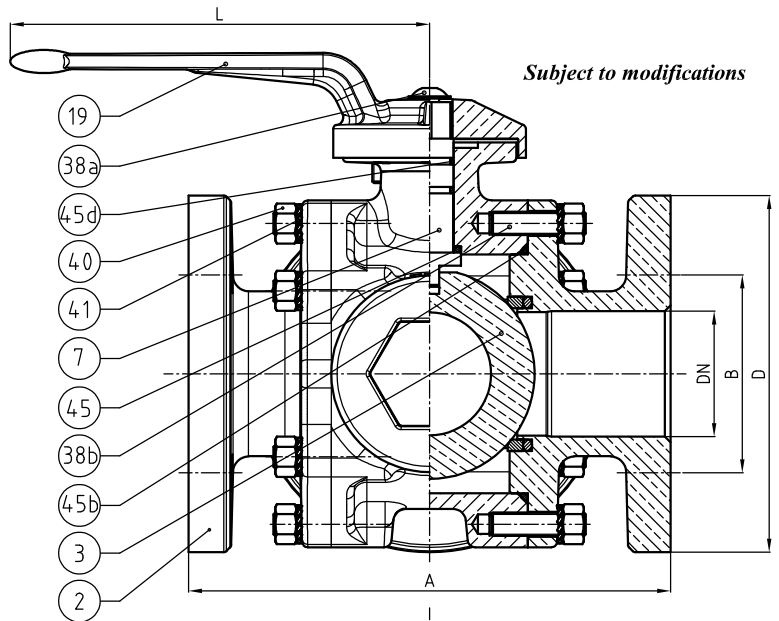

NOMENCLATURE			
Rep	Qty	Designation	Material
1	1	BODY	ALUMINIUM BRONZE
2	2	COVER	ALUMINIUM BRONZE
3	1	BALL	ALUMINIUM BRONZE
6	2	SEAT	PTFE
7	1	STEM	ALUMINIUM BRONZE
19	1	HANDLE	ALUMINIUM BRONZE
37	1	PLUG	ALUMINIUM BRONZE
38a	1	SCREW	STAINLESS STEEL A4-70
38b	12	SCREW	STAINLESS STEEL A4 21H
40	12	NUT	STAINLESS STEEL A4-70
41	12	WASHER	STAINLESS STEEL A4
45	1	GASKET	PTFE
45a	1	O-RING	FPM
45b	2	O-RING	FPM
45c	4	O-RING	FPM
45d	2	O-RING	FPM
60	1	SPRING PLUNGERS	STAINLESS STEEL A1

DIMENSIONS	
DN	65
A (mm)	250
B (mm)	145
C (mm)	108
D (mm)	185
H (mm)	168
L (mm)	218
Base ISO	F07
S (mm)	17
Maximum torque (N.m)	40*
Weight (Kg)	30.100

*Under reserve

REFERENCES NORMS :

- Material : NF EN 1982 - NF EN 12163 - NF EN 12164 - NF EN 10272
- Testing & checking : NF EN 12266-1/-2 (bench test)
- Flanges : NF EN 1092-3

Ref. instruction of assembling : 0904DA157E

Ref. instruction of operation : 0904DA158E

Mounting & assembly guides are available on our website.

These data are for information and can be modified without notice. It is not up to us to appreciate specifications. It is up to the customer to verify the adequacy between the equipment chosen and the real conditions of use.