



AUTEXIER

**MANUFACTURER OF INDUSTRIAL MARINE AND OIL & GAS VALVES
IN BRONZE AND ALUMINIUM-BRONZE**

93, rue Louis Blanc - 02300 CHAUNY - FRANCE

Tel: +33 (0)3.23.52.02.86 - Fax: +33 (0)3.23.39.52.28

www.autexier.fr

Instructions of assembly and maintenance for visual level controller



149, 150, 249, 250, 449, 450, 184, 186, 2184, 3184, 276, 278, 2276, 274, 275, 277, 349 and 350

I) Checking at the delivery

Check at receipt that the packaging has not been damaged, that the delivered visual level controller is in accordance with your order and that the material is not damaged.

II) Storage

The visual level controllers can reach the site several months before commissioning. Performance may be degraded if special care is not taken in their storage and protection.

It is recommended to store the visual level controllers in a clean, closed, protected from weather and projections of sand, dust and other solid particles. Leave them as much as possible in their original packaging. The plugs, protections threads, plastic envelopes, will be removed at the time of installation. Avoid impacts on the sealing surfaces of the threads.

III) Assembly of the visual level controller

- 1) The visual level controllers must be handled with particular care. Prevent the ingress of foreign bodies in the visual level controllers reflex glass indicators during installation and operation.
- 2) This equipment can not be installed in an explosive area.

IV) Instructions

- 1) It is strictly forbidden to neutralize the mechanism of the visual level controllers.
- 2) Any foreign body must block the entries of the visual level controllers.
- 3) The visual level controllers must be installed in a place where there is no risk of shock or water hammer which would endanger working.
- 4) Insulate the equipment if the temperature of contact requires it (for staff in case of explosive atmosphere in or out of the equipment), and allow only the access to the approved staff. For the equipment, it is imperative to stay in a beach temperature indicated on the identification plate or failing on the product data sheet. Take care not to have fluid in changing state (gel) may damage the tube.
- 5) It is imperative to respect the conditions of use stated (pressure, temperature, fluid) during your request to our services (no corrosive fluids or fluids which may cause significant wear, no unstable fluids from which decomposition may cause risk, do not use several fluids likely to react each other to generate derivatives leading to an explosive atmosphere or may not viscous fluids solidify at a moment or another).
- 6) Limit as much as possible the tensions due to failure alignments of the piping connections system.
- 7) It is necessary to eliminate any previous and post pressure before removing the level indicator and be sure not to create an explosive inside or outside the reflex glass indicator. The staff operating the setting up of the visual level controller will be trained to perform this operation and will wear all necessary protections linked to the carried fluid.
- 8) Do not let the mechanism in intermediate position for a long time to avoid any phenomenon of cavitation and/or erosion.



9) Do not modify the documents furnished by AUTEXIER (instructions, metal plates, certificates etc.).

CAUTION: AUTEXIER is not anymore responsible of the good working of the level indicator if this one has been dismantled or modified by a person not approved by AUTEXIER.

V) Operating / Maintenance

1) It is imperative to maintain the visual level controller clean and ready to operate. This includes checking periodically that no foreign body clogs the pipes and that the installation is free as possible of deposits and impurities.

2) For references 149/249/449, 150/450, 184, 3184, 2276, 276 and 278 the packing gland (parts 12, 13 and 14) is mounted by us at the factory. However, during the life of the equipment, it may be necessary to tighten *packing nut 14*; or to change of the *packing 12*.

To do this, after taking care to let the material to ambient temperature and making sure that the system has been correctly purged, unscrew the *nut 40*, remove the *handwheel 8* unscrew the *packing nut 14* remove the *packing gland 13*, remove the sealing gasket 12, put new packing in the *bonnet 2*, replace the *packing gland 13*, screw *packing nut 14*, put the *handwheel 8*, screw the *nut 40*. Packing glands must be tightened at the setting up of operation and just enough to seal.

This maintenance should be carried out by qualified and duly authorized staff. This disassembly reassembly is the only one authorized by AUTEXIER under conditions that parts are supplied by us, that the handling of the equipment is made at ambient temperature, that the operator uses material in accordance with the classification of the area in which it operates (potentially explosive), and it is well assured that the system has been properly purged beforehand, without creating an explosive atmosphere during operation.

VI) Guarantee

All our products are guaranteed during twelve months from the delivery against any defect of material or manufacturing, when the conditions of use are respected: this guarantee is limited to the replacement or to the repair by our company of the defective recognized parts. We decline all responsibility in case of non respect with our instructions.

Ref. 149 / 249 / 449

Ref. 150 / 250 / 450

Ref. 184

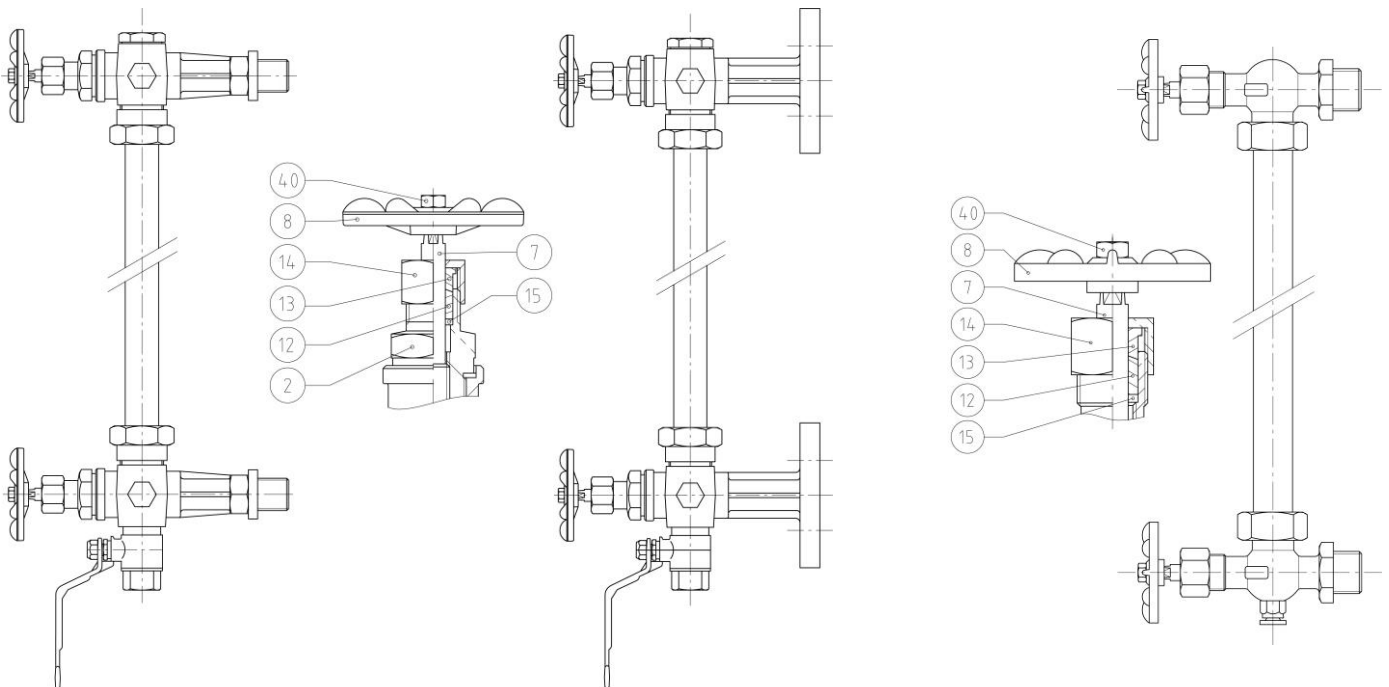

Ref. 186

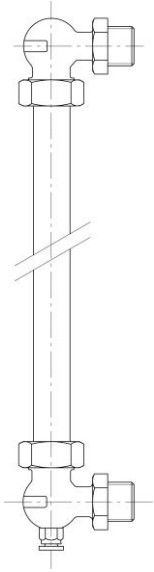

Ref. 2184

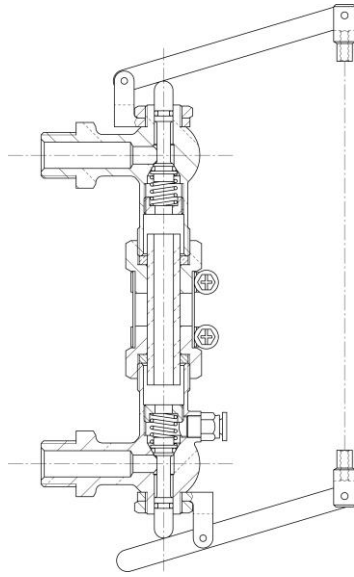

Ref. 3184

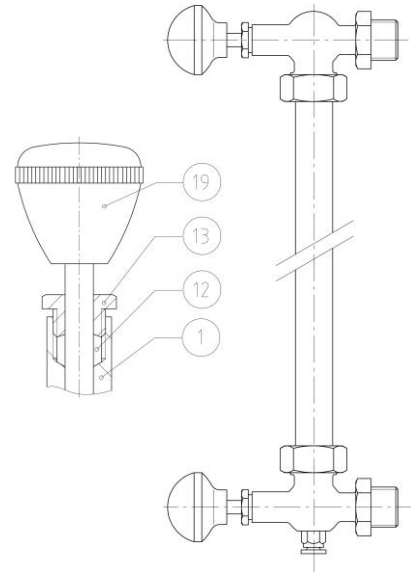

Ref. 2276

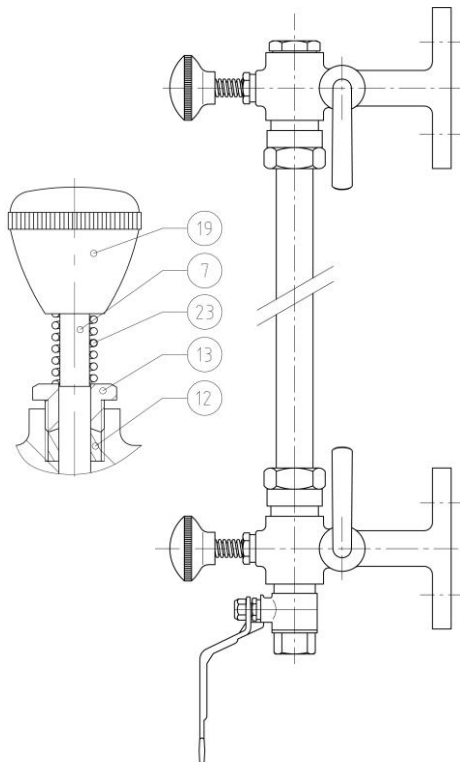

Ref. 276

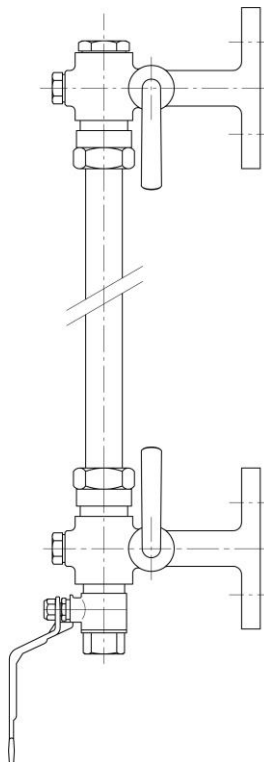

Ref. 278

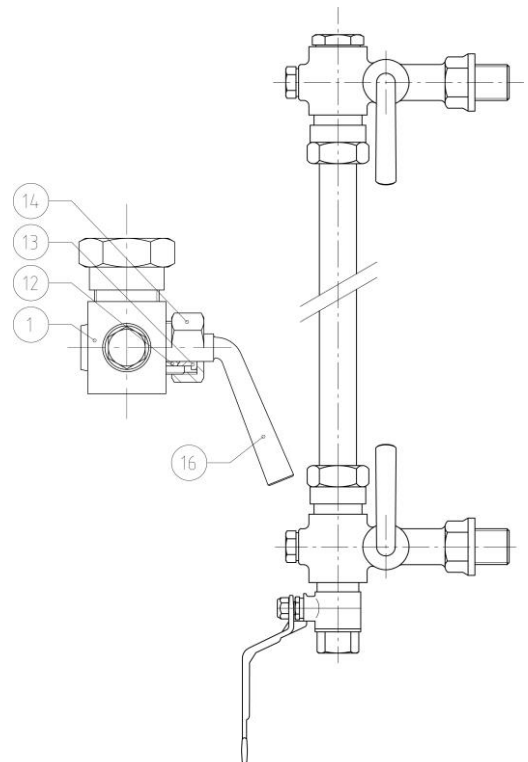



VII) Marking

After being tested and adjusted, each visual level controller is sealed by AUTEXIER. If another agency makes a mark by punching the visual level controller should not be damaged. Poorly executed, deformations could make tap fugitive, or inoperative. Punching of thin walls is prohibited.

Level indicators are identified by a label with the following information:

- The date of shipment
- Specifications:
 - 1 - Designation: Reference of visual level controller
 - 2 - Number of the linked document and du number of declaration of conformity to directive 2014/68/EU
 - 3 - Inlet nominal diameter and outlet nominal diameter
 - 4 - Maximum conditions of use
 - 5 - Envelope pressure test
 - 6 - Safety pressure
 - 7 - Set pressure (xx for this product)
 - 8 - Group of fluid G for Gas / L for Liquid or S for Steam
- If requirement, **CE** marking with number of identifying the notified body 0094 (LRQA)

 AUTEXIER <small>FABRICANT EN ROBINETTERIE INDUSTRIELLE 93 RUE LOUIS BLANC / 02300 CHAUNY FRANCE / + 33 (0)3 23 52 02 86</small>		<i>jj/mm/aa :</i>	
<i>Désignation :</i> 1		<i>N° Doc. :</i> 2	<i>Dcl :</i> 2
○	<i>Entrée (Inlet) : DN</i> 3	<i>Sortie (Outlet) : DN</i> 3	
	<i>PN (NP) : 4 Bar</i>	<i>TS (Mini./Max.) :</i> 4	°C
<i>Pression d'essais (Test pressure) PT :</i> 5 Bar			 0094
<i>Pression maximale admissible (Safety pressure) PS :</i> 6 Bar			
<i>Pression de tarage (Set pressure) PDO :</i> 7 Bar			
<i>Groupe de fluide (Group of fluid) :</i> 1 → 8			

It is imperative to respect the conditions of use stated on the rating plate (pressure, temperature, and fluid) under penalty of equipment damage and void the warranty.

Ref. Document 0904DA140E version 03 of 03 February 2025

