



AUTEXIER

**MANUFACTURER OF INDUSTRIAL MARINE AND OIL & GAS VALVES
IN BRONZE AND ALUMINIUM-BRONZE**

93, rue Louis Blanc - 02300 CHAUNY - FRANCE

Tel: +33 (0)3.23.52.02.86 - Fax: +33 (0)3.23.39.52.28

www.autexier.fr

Instructions of assembly and maintenance for gate valves



89, AU89, 90, AU90, 91, AU91, 191, 191TB, A191, AU191, A191A / AE / AS, A191B / BE / BS, A191C / CE / CS, A191D / DE / DS, A191H, A2191A / AE / AS, A2191B / BE / BS, A2191C / CE / CS, A2191D / DE / DS, A3191A / AE, A3191B / BE, A3191C / CE, A3191D / DE, A3192A / AE, A3192B / BE, A3192C / CE and A3192D / DE

I) Checking at the delivery

Check at receipt that the packaging has not been damaged, that the delivered valve is in accordance with your order and that the material is not damaged.

II) Storage

The valves can reach the site several months before commissioning. Performance may be degraded if special care is not taken in their storage and protection.

It is recommended to store the valves in a clean, closed, protected from weather and projections of sand, dust and other solid particles. Leave them as much as possible in their original packaging. The plugs, protections threads, plastic envelopes, will be removed at the time of installation. Avoid impacts on the sealing surfaces of the flanges and threads.

III) Assembly of the valve

- 1) The valves must be handled with particular care. The sealing surfaces of the valve plug and seat are finely machined to obtain the required tightness. Prevent the ingress of foreign bodies in the valve during installation and operation.
- 2) During assembly or maintenance, if the valve is located in an explosive area, use a material in accordance with the explosive classification of this area, without insulating it electrically from the rest of the system to avoid any electrostatic phenomenon.

IV) Instructions

- 1) Do not neutralize the valve mechanism.
- 2) Any foreign body should block the openings of the valve. Do not let any viscous fluids or fluids that can leave residue by drying penetrate inside the valve, which would cause a flow jam or block the mechanism.
- 3) The valve should be installed in a place where there is no risk of shock or water hammer which could damage its working.
- 4) If the temperature is lower than 0°C or superior to 60°C, it is necessary to insulate the material and to authorize its access only to the authorized staff.
For the material, it is imperative to stay in a temperature indicated on the identification plate or failing on the product data sheet.
- 5) It is imperative to respect the defined conditions announced by our staff (pressure, temperature, and fluid). Do not use corrosive fluids or fluids likely to provoke a significant wear, no unstable fluid with risky decomposition; do not use several fluids which could react altogether or release derivatives leading to an explosive atmosphere and no viscous fluids likely to solidify at one moment or another.
- 6) Limit as much as possible the tensions due to failure alignments of the piping connections system.



- 7) It is necessary to eliminate any previous and post pressure before removing the valve and be sure not to create an explosive inside or outside the valve. The staff operating the setting up of the valve will be trained to perform this operation and will wear all necessary protections linked to the carried fluid.
- 8) Do not let the mechanism in intermediate position for a long time to avoid any phenomenon of cavitation and/or erosion.
- 9) Do not modify the documents furnished by AUTEXIER (instructions, metal plates, certificates etc.).

CAUTION: AUTEXIER is not anymore responsible of the good working of the valve if this one has been dismantled or modified by a person not approved by AUTEXIER.

V) Operating / Maintenance

1) It is imperative to maintain the valve clean and in good working conditions. It is necessary to check periodically that no foreign body blocks the piping and that the installation is free of deposits and impurities.

2) The packing gland system (parts 12, 13 and 14) is assembled by our staff in our factory. However, during the valve's lifetime, it can be necessary to tighten the *packing nut 14*; or to replace the *packing 12*.

Before you perform this operation, take care to let the material come back to an ambient temperature and make sure that the installation is correctly purged.

Untighten the *nut 40*, remove the *wheel 8*, undo the *packing nut 14*, remove the *packing gland 13*, remove the *packing 12*, set up the new packing inside the *bonnet 2*, put the *packing gland 13* back on, screw the *packing nut 14*, set the *wheel 8* back and screw the *nut 40*.

The packing gland systems must be tightened when the valve is going to be used and just enough to ensure tightness.

This maintenance operation must be carried out by a skilled and authorized staff. This operation of dismantle and reassembly is the only one authorized by AUTEXIER under the condition that this packing is sold by the company AUTEXIER, the handling is done at an ambient temperature, the operator uses an equipment adapted to the classification of the working area (explosive risk) and make sure that the installation was correctly purged beforehand without creating an explosive atmosphere.

VI) Guarantee

All our products are guaranteed during twelve months from the delivery against any defect of material or manufacturing, when the conditions of use are respected: this guarantee is limited to the replacement or to the repair by our company of the defective recognized parts. We decline all responsibility in case of non respect with our instructions.

Ref. 89 / AU89

Ref. 90 / AU90

Ref. 91 / AU91

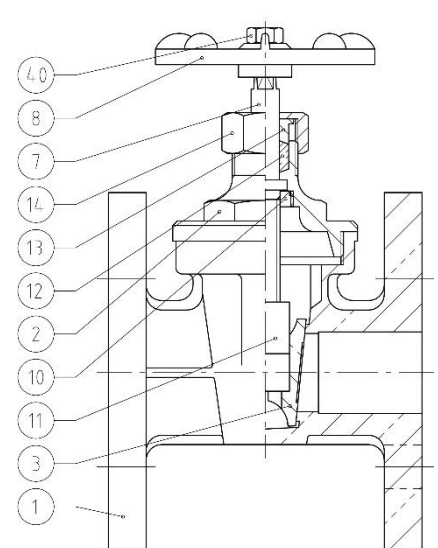
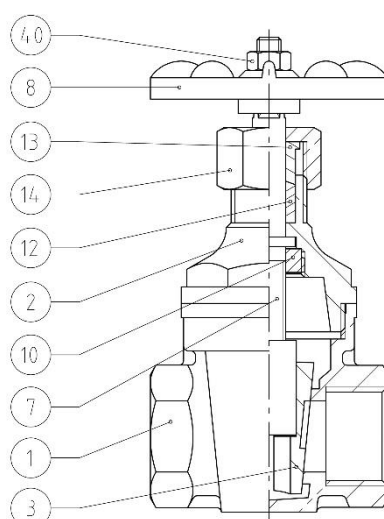
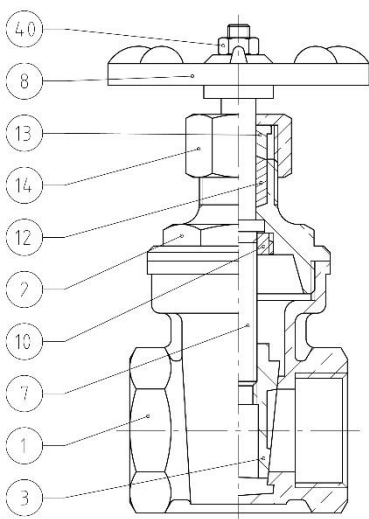

Ref. 191 / AU191

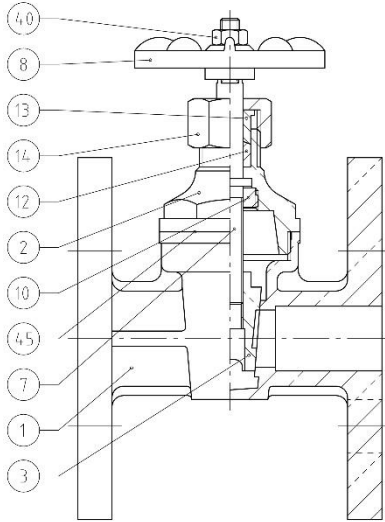

Ref. A1191 / A1191

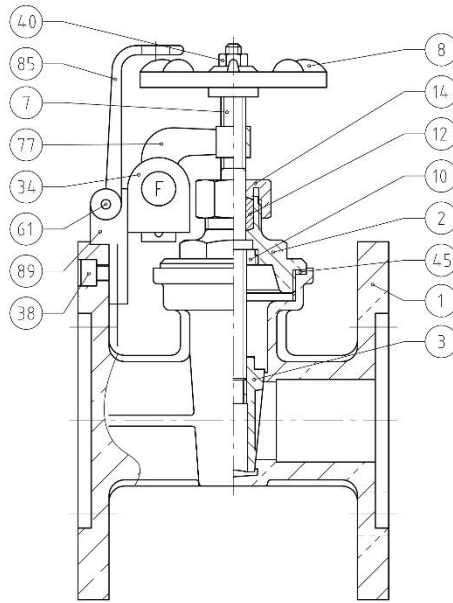

Ref. A2191

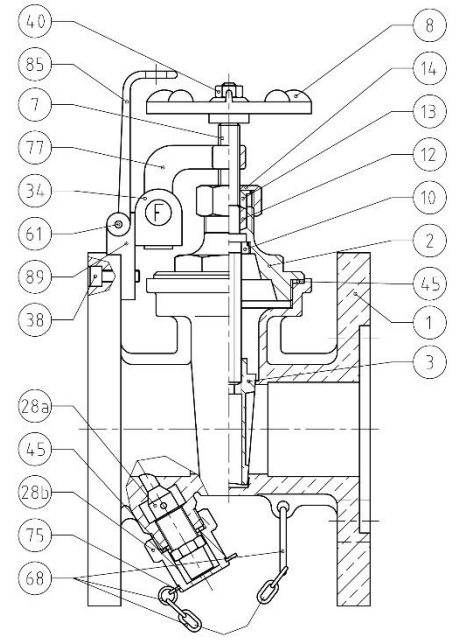

Ref. A3191

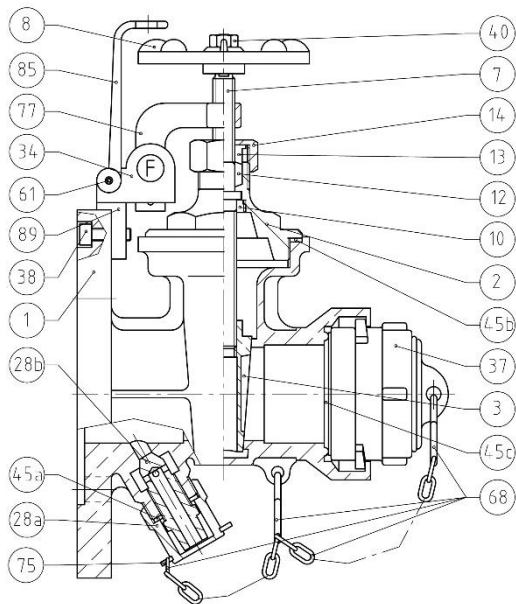

Ref. A3192

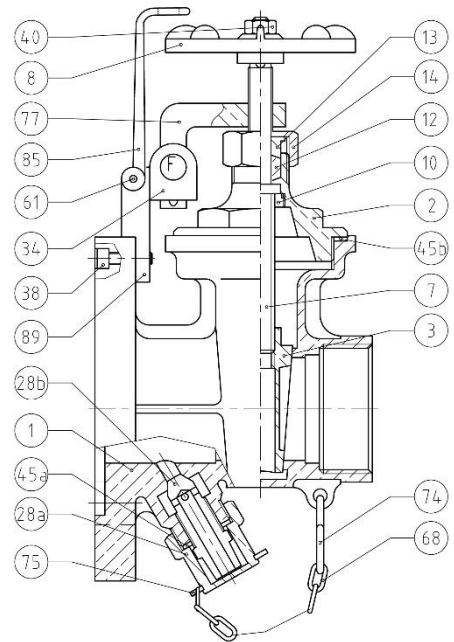



VII) Marking

After being tested and adjusted, each valve is sealed by AUTEXIER. If another agency makes a mark by punching the valve should not be damaged. Poorly executed, deformations could make tap fugitive, or inoperative. Punching of thin walls is prohibited.

Valves are identified by a label with the following information:

- The date of shipment
- Specifications:
 - 1 - Designation: Reference of valve
 - 2 - Number of the linked document and number of declaration of conformity to directive 2014/68/EU
 - 3 - Inlet nominal diameter and outlet nominal diameter
 - 4 - Maximum conditions of use
 - 5 - Envelope pressure test
 - 6 - Safety pressure
 - 7 - Set pressure (xx for this product)
 - 8 - Group of fluid G for Gas / L for Liquid or S for Steam
- If requirement, **CE** marking with number of identifying the notified body 0094 (LRQA)

 AUTEXIER <small>FABRICANT EN ROBINETTERIE INDUSTRIELLE 93 RUE LOUIS BLANC / 02300 CHAUNY FRANCE / + 33 (0)3 23 52 02 86</small>		<i>jj/mm/aa :</i>	
<i>Désignation :</i> 1		<i>N° Doc. :</i> 2	<i>Dcl :</i> 2
○	<i>Entrée (Inlet) : DN</i> 3		<i>Sortie (Outlet) : DN</i> 3
	<i>PN (NP) : 4 Bar</i>		<i>TS (Mini./Max.) : 4 °C</i>
<i>Pression d'essais (Test pressure) PT :</i> 5 Bar			 0094
<i>Pression maximale admissible (Safety pressure) PS :</i> 6 Bar			
<i>Pression de tarage (Set pressure) PDO :</i> 7 Bar			
<i>Groupe de fluide (Group of fluid) :</i> 1 → 8			

It is imperative to respect the conditions of use stated on the rating plate (pressure, temperature, and fluid) under penalty of equipment damage and void the warranty.

Ref. Document 0904DA121E version 06 of 27 January 2025

