



**AUTEXIER**

**MANUFACTURER OF INDUSTRIAL MARINE AND OIL & GAS VALVES  
IN BRONZE AND ALUMINIUM-BRONZE**

93, rue Louis Blanc - 02300 CHAUNY - FRANCE  
Tel: +33 (0)3.23.52.02.86 - Fax: +33 (0)3.23.39.52.28  
[www.autexier.fr](http://www.autexier.fr)

## Instruction for use for swing check valves



**109B, AU19B, 109M AU109M, 110B, AU110B, 110M and AU110M**

### Operation

When the fluid flows in the direction of arrow stamped on the *body 1*, it pushes the leaf and carries the opening mechanism. By opening this beating pivots about the *axis 81* through the *lever 20*. Assuming that the fluid is stationary, beating will close itself. By cons, if the direction of fluid flow is in the opposite direction, it tends to press the *disc 4* against its support in the *body 1* and therefore the fluid flow is completely blocked.

Ref. 109 / AU109

Ref. 110 / AU110

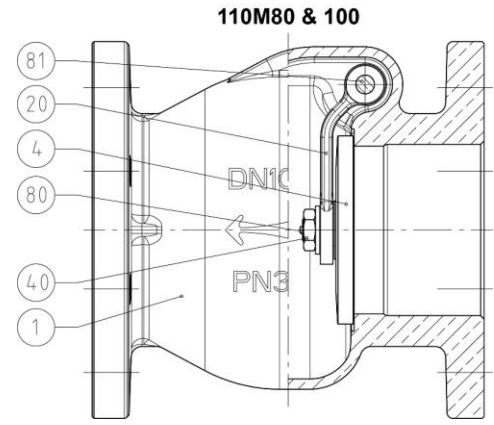
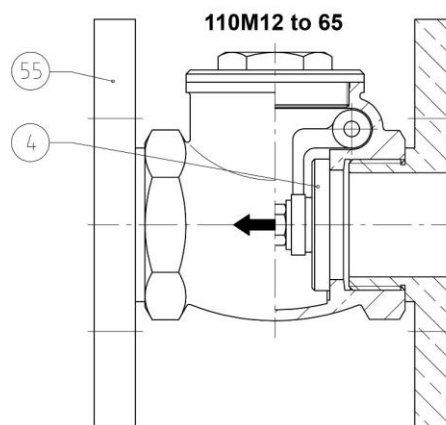
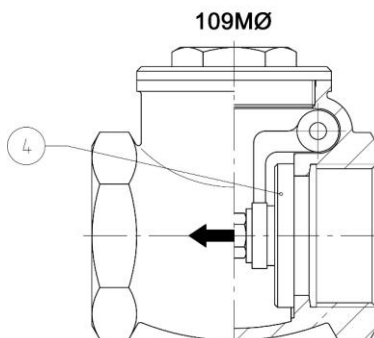
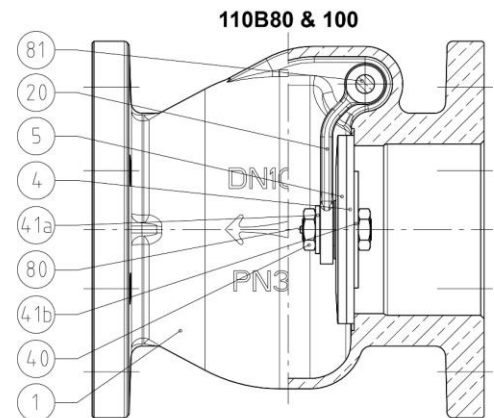
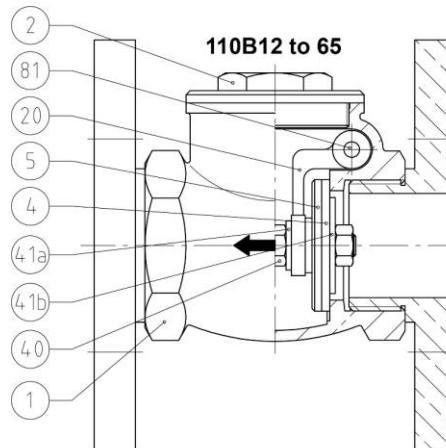
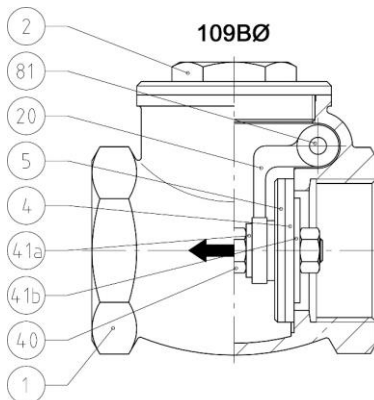

Ref. Document 0904DA083E version 02 of 27 January 2025

