



AUTEXIER

MANUFACTURER OF INDUSTRIAL VALVES

93 Rue Louis Blanc - 02300 CHAUNY - FRANCE
 Phone : +33 (0)3 23 52 02 86 Fax : +33 (0)3 23 39 52 28
 Website : www.autexier.fr

Ref. A3202 Family : 46

Rev. 05

Date : 25 Nov. 2024

Page 1/1

BRONZE FIRE HYDRANT STRAIGHT PATTERN VALVE

Ref. A3202.Ø

SERIES :

- A3202.Ø

For material compatibility, contact us

CHARACTERISTICS :

- PN16 (Nominal Pressure)
- ENDS : Flange ISO PN16 / Guillemín or Storz outlet coupling
- MATERIAL : BRONZE CC491K

MAXIMUM CONDITIONS OF USE :

- 16 bar of -15°C to 100°C

APPLICATIONS :

- Fire networks

OPTIONS :

- Tap drain valve
- Double tightness packing
- Special drilling
- Plug drilling on demand

Specific dimensions, contact us



*Subject to modifications
 Photo for information only*

NOMENCLATURE			
Rep	Qty	Designation	Material
1	1	BODY	BRONZE
2	1	BONNET	BRONZE
4	1	DISC	NBR
5	1	DISC HOLDER	BRONZE
7	1	STEM	BRASS
8	1	HANDWHEEL	ALUMINIUM ALLOY
37	1	PLUG	BRONZE
40a	1	NUT	STAINLESS STEEL A4
40b	1	NUT	STAINLESS STEEL A4
41a	1	WASHER	BRASS
41b	1	WASHER	STAINLESS STEEL A4
45a	1	GASKET	NBR
45b	1	O-RING	FPM
45c	1	O-RING	FPM
52	1	TAP DRAIN VALVE*	BRASS
68	1	CHAIN	STAINLESS STEEL A4
69	1	FITTING	BRONZE

**Optional*

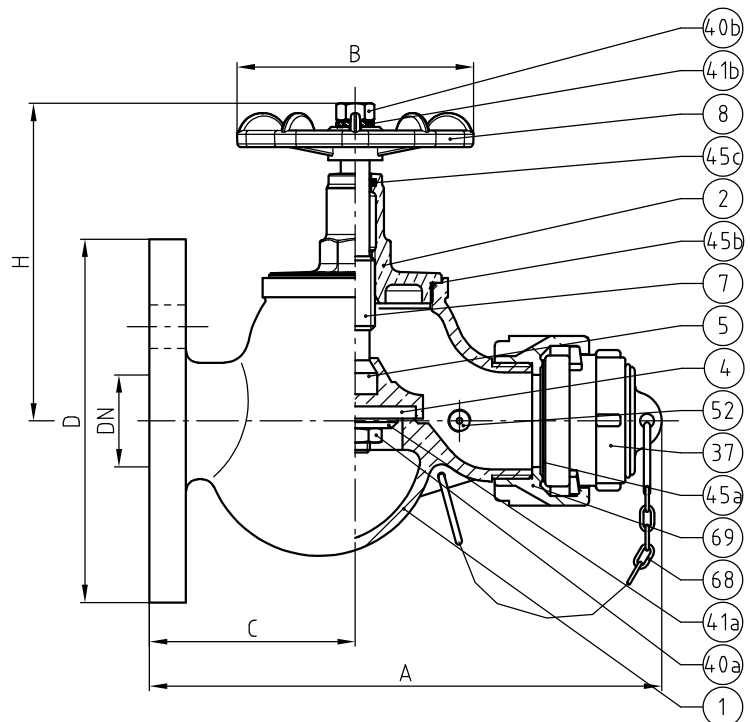

DIMENSIONS		
DN	40	50
A (mm)	212	212
B (mm)	110	110
C (mm)	85	85
D (mm)	150	165
H (mm)	134	134
Weight (Kg)	5.300	6.000

REFERENCES NORMS :

- Material : NF EN 1982 - NF EN 12163 - NF EN 12164 - NF EN 10272
- Testing & checking : NF EN 12266-1/-2 (bench test)
- Flange : NF EN 1092-3
- Fitting : NF E 29-572 / DIN 14 307/311

Ref. instruction of assembling : 0904DA119E

Ref. instruction of operation : 0904DA120E

Mounting & assembly guides are available on our website.

These data are for information and can be modified without notice. It is not up to us to appreciate specifications. It is up to the customer to verify the adequacy between the equipment chosen and the real conditions of use.