



AUTEXIER

MANUFACTURER OF INDUSTRIAL VALVES

93 Rue Louis Blanc - 02300 CHAUNY - FRANCE
Phone : +33 (0)3 23 52 02 86 Fax : +33 (0)3 23 39 52 28
Website : www.autexier.fr

Ref. A74 Family : 49

Rev. 00

Date : 07 Oct. 2024

Page 1/1

BRONZE BALL VALVE Ref. A74.25DM

SERIES :

- A74

For material compatibility, contact us

CARACTERISTICS :

- PN16 (Nominal Pressure)
- ENDS : ISO PN16 Flanges and BSP female thread
- MATERIAL : BRONZE CC491K

MAXIMUM CONDITIONS OF USE :

- 16 bar of -15°C to 100°C

APPLICATIONS :

- Water-based fluids
- Oil & gas

OPTIONS :

- Special drilling
- Monel Trim

Specific dimensions, contact us

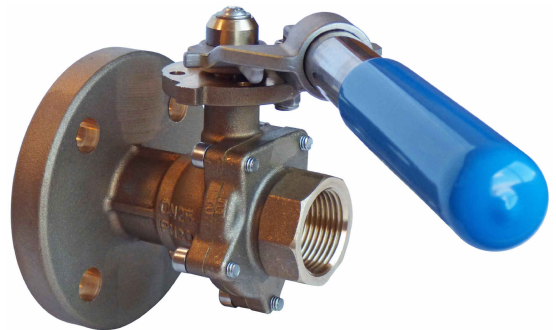

Subject to modifications

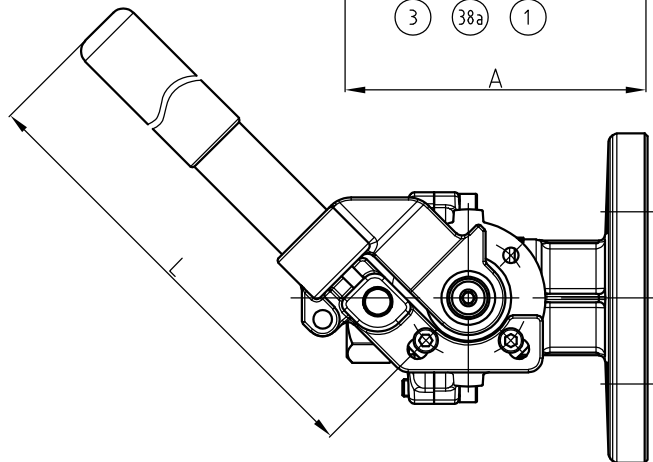
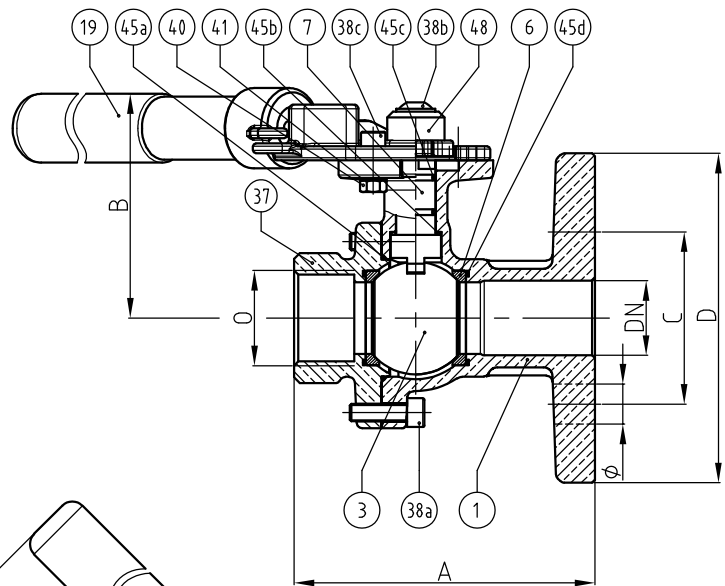

NOMENCLATURE

Rep	Qty	Designation	Material
1	1	BODY	BRONZE
3	1	SHUTTER	ALUMINIUM BRONZE
6	2	SEAT	PTFE
7	1	STEM	ALUMINIUM BRONZE
19	1	HANDLE	STAINLESS STEEL 304
37	1	PLUG	BRONZE
38a	5	SCREW	STAINLESS STEEL A4-70
38b	1	SCREW	STAINLESS STEEL A4-70
38c	2	SCREW	STAINLESS STEEL A2-70
40	2	NUT	STAINLESS STEEL A2
41	2	WASHER	STAINLESS STEEL A2
45a	1	O-RING	FPM
45b	1	GASKET	PTFE
45c	2	GASKET	FPM
45d	2	O-RING	FPM
48	1	SPACER	ALUMINIUM BRONZE

REFERENCES NORMS :

- Material : NF EN 1982 - NF EN 12163 - NF EN 12164 - NF EN 10272
- Testing & checking : NF EN 12266-1/-2 (bench test)
- Flange : NF EN 1092-3
- Female thread : ISO 228-1

Ref. instruction of assembling : 0904DA135E

Ref. instruction of operation : 0904DA136E

Mounting & assembly guides are available on our website.

DIMENSIONS

DN	25
A (mm)	105
B (mm)	80
C (mm)	85
D (mm)	115
L (mm)	225
O	G 1"
Ø Drilling	4x14
Weight (Kg)	3.000

These data are for information and can be modified without notice. It is not up to us to appreciate specifications. It is up to the customer to verify the adequacy between the equipment chosen and the real conditions of use.