



AUTEXIER

MANUFACTURER OF INDUSTRIAL VALVES

93 Rue Louis Blanc - 02300 CHAUNY - FRANCE
Phone : +33 (0)3 23 52 02 86 Fax : +33 (0)3 23 39 52 28
Website : www.autexier.fr

Ref. 189 Family : 27

Rev. 16

Date : 30 Jan. 2024

Page 1/1

BRONZE SAFETY VALVE

Ref. 189.Ø / 189BPØ / 189T.Ø

SERIES :

- 189 : FPM disc
- 189BP : Silicone disc (low pressure)
- 189T : PTFE disc
- Male inlet / female outlet

For material compatibility, contact us

CARACTERISTICS :

- PN40 (Nominal Pressure)
- ENDS : GAZ threads
- MATERIAL : BRONZE CC491K

MAXIMUM CONDITIONS OF USE :

- Ref. 189 : 40 bar of -15°C to 200°C
- Ref. 189BP: 40 bar of -50°C to 200°C
- Ref. 189T : 40 bar of -50°C to 225°C

APPLICATIONS :

- Hot water & Industrial fluids
- Water-based fluids
- Steam up to 8 bar (FPM)
- Steam 8 to 15 bar (PTFE / Metal)
- Neutral gases (compressed air,...)

OPTIONS :

- Nickel coating
- Flange connection
- NPT connection
- Degreased disc / seat

Specific dimensions, contact us

DIMENSIONS				
DN	15	20	25	32
A (mm)	74	85	100	122
B (mm)	12	14	16	18
C (mm)	30	35	40	45
D	1/2	3/4	1"	1"1/4
E (mm)	28	35	39	43
O	1/2	3/4	1"	1"1/4
Weight (Kg)	0.335	0.560	0.934	1.405
S Inlet (mm ²)	103.8	226.9	490.6	706.9
S Outlet (mm ²)	272.6	456.8	720.6	1191.6

REFERENCES NORMS :

- Material : NF EN 1982 - NF EN 12163 - NF EN 12164 - NF EN 10272
- Testing & checking : NF EN 12266-1/-2 (bench test)

Ref. instruction of assembling : 0904DA091E

Ref. instruction of operation : 0904DA153E

Mounting & assembly guides are available on our website.



Subject to modifications

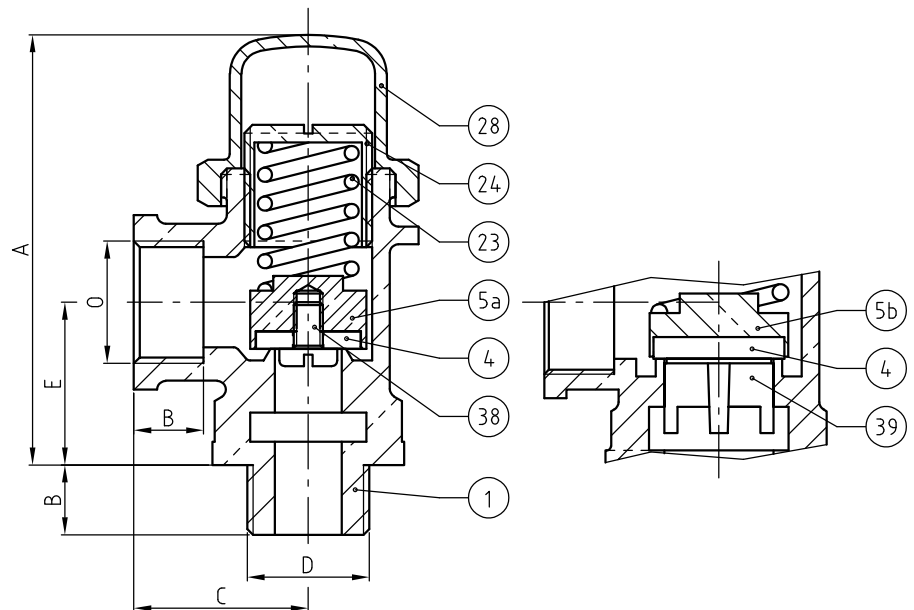

NOMENCLATURE			
Rep	Qty	Designation	Material
1	1	BODY	BRONZE
4	1	DISC	189:FPM/189BP:Silicone/189T:PTFE
5a	1	DISC HOLDER (DN15 to DN25)	BRASS
5b	1	DISC HOLDER (DN32)	BRONZE
23	1	SPRING	STAINLESS STEEL
24	1	ADJUSTING SCREW	BRASS
28	1	CAP	BRONZE
38	1	SCREW (DN15 / DN20)	STAINLESS STEEL
39	1	FIN (DN25 / DN32)	BRONZE

These data are for information and can be modified without notice. It is not up to us to appreciate specifications. It is up to the customer to verify the adequacy between the equipment chosen and the real conditions of use.