



AUTEXIER

MANUFACTURER OF INDUSTRIAL VALVES

93 Rue Louis Blanc - 02300 CHAUNY - FRANCE
 Phone : +33 (0)3 23 52 02 86 Fax : +33 (0)3 23 39 52 28
 Website : www.autexier.fr

Ref. A112 Family : 20

Rev. 07

Date : 14 Dec. 2022

Page 1/1

BRONZE SWING CHECK VALVE Ref. A112ØD

SERIES :

- A112ØD : Inlet / outlet flanged
- Full bore
- Oblique seat : 15°

For material compatibility, contact us

CARACTERISTICS :

- PN16 (Nominal Pressure)
- ENDS : Loose flanges ISO PN10
- MATERIAL : BRONZE CC491K

MAXIMUM CONDITIONS OF USE :

- 16 bar of -15°C to 120°C

APPLICATIONS :

- Water-based fluids
- Steam (8 bar)
- Seawater

OPTIONS :

- Special drilling

Specific dimensions, contact us



Subject to modifications

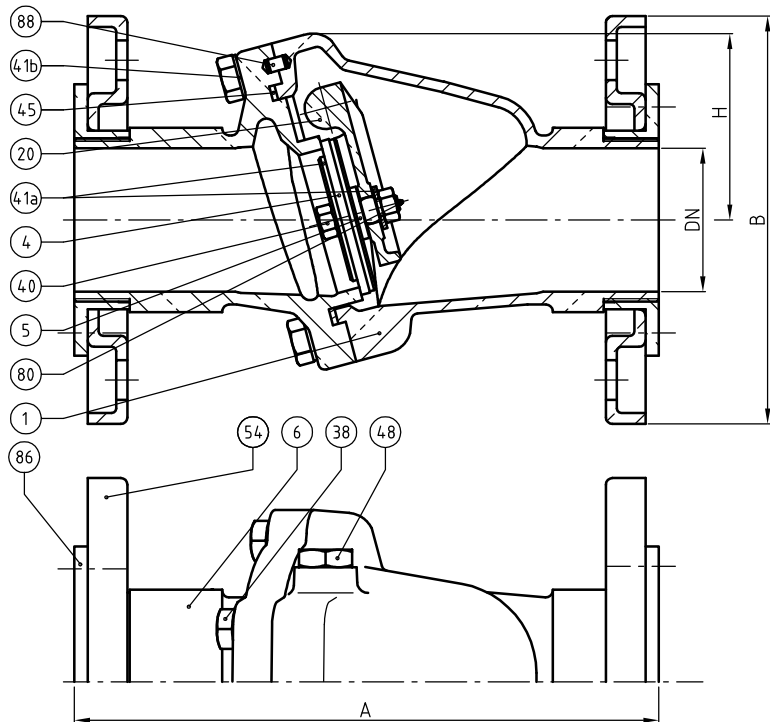

DIMENSIONS				
DN	A (mm)	B (mm)	H (mm)	n
32	180	140	67	5
40	195	150	72	5
50	223	165	85	5
65	265	185	85	6
80	295	200	98	7
100	305	220	111	7
125	370	250	144	8
150	420	285	157	8
200	515	340	173	9

REFERENCES NORMS :

- Material : NF EN 1982 - NF EN 12163 - NF EN 12164 - NF EN 10272
- Testing & checking : NF EN 12266-1/-2 (bench test)
- Flanges : NF EN 1092-3

Ref. instruction of assembling : 0904DA139E

Ref. instruction of operation : 0904DA089E

Mounting & assembly guides are available on our website.

NOMENCLATURE			
Rep	Qty	Designation	Material
1	1	BODY	BRONZE
4	1	DISC	FPM
5	1	DISC HOLDER	ALUMINIUM BRONZE
6	1	SEAT	BRONZE
20	1	LEVER	ALUMINIUM BRONZE
38	n	SCREW	STAINLESS STEEL
40	1	NUT	STAINLESS STEEL
41a	1	WASHER	ALUMINIUM BRONZE
41b	n	WASHER	STAINLESS STEEL
45	1	GASKET	FPM
48	1	SLEEVE	ALUMINIUM BRONZE
54	2	LOOSE FLANGE	STAINLESS STEEL
80	1	CUSHION	POLYURETHANE
86	2	COLLAR	ALUMINIUM BRONZE
88	1	CENTRING PIN	ALUMINIUM BRONZE

These data are for information and can be modified without notice. It is not up to us to appreciate specifications. It is up to the customer to verify the adequacy between the equipment chosen and the real conditions of use.