



AUTEXIER

MANUFACTURER OF INDUSTRIAL VALVES

93 Rue Louis Blanc - 02300 CHAUNY - FRANCE
 Phone : +33 (0)3 23 52 02 86 Fax : +33 (0)3 23 39 52 28
 Website : www.autexier.fr

Ref. A112 Family : 20

Rev. 05

Date : 14 Dec. 2022

Page 1/1

BRONZE SWING CHECK VALVE Ref. A112ØC/C1

SERIES :

- A112ØC : Inlet / outlet smooth finish
- Full bore
- Oblique seat : 15°

For material compatibility, contact us



CARACTERISTICS :

- PN16 (Nominal Pressure)
- ENDS : Smooth finish
- MATERIAL : BRONZE CC491K

MAXIMUM CONDITIONS OF USE :

- 16 bar of -15°C to 120°C

APPLICATIONS :

- Water-based fluids
- Steam (8 bar)
- Seawater

OPTIONS :

- Socket welding
- Coupling Victaulic® ou Straub®

Specific dimensions, contact us



Subject to modifications

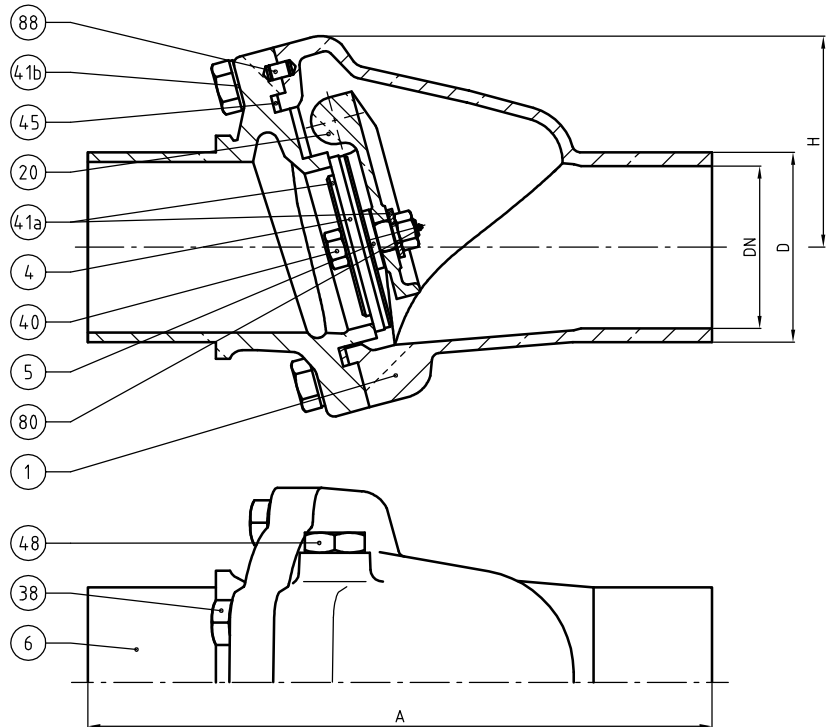

DIMENSIONS

DN	A (mm)	D (mm) Ref.A1120C	D (mm) Ref.A1120C1	H (mm)	n
32	165	38	-	67	5
40	180	48.3	44.5	72	5
50	208	57	-	85	5
65	250	76.1	-	85	6
80	270	88.9	84	98	7
100	290	108	-	111	7
125	353	133	-	144	8
150	398	159	-	157	8
200	493	219	-	173	9

NOMENCLATURE

Rep	Qty	Designation	Material
1	1	BODY	BRONZE
4	1	DISC	FPM
5	1	DISC HOLDER	ALUMINIUM BRONZE
6	1	SEAT	BRONZE
20	1	LEVER	ALUMINIUM BRONZE
38	n	SCREW	STAINLESS STEEL
40	1	NUT	STAINLESS STEEL
41a	1	WASHER	ALUMINIUM BRONZE
41b	n	WASHER	STAINLESS STEEL
45	1	GASKET	FPM
48	1	SLEEVE	ALUMINIUM BRONZE
80	1	CUSHION	POLYURETHANE
88	1	CENTRING PIN	ALUMINIUM BRONZE

REFERENCES NORMS :

- Material : NF EN 1982 - NF EN 12163 - NF EN 12164 - NF EN 10272
- Testing & checking : NF EN 12266-1/-2 (bench test)

Ref. instruction of assembling : 0904DA139E

Ref. instruction of operation : 0904DA089E

Mounting & assembly guides are available on our website.

These data are for information and can be modified without notice. It is not up to us to appreciate specifications. It is up to the customer to verify the adequacy between the equipment chosen and the real conditions of use.