



AUTEXIER

MANUFACTURER OF INDUSTRIAL VALVES

93 Rue Louis Blanc - 02300 CHAUNY - FRANCE
 Phone : +33 (0)3 23 52 02 86 Fax : +33 (0)3 23 39 52 28
 Website : www.autexier.fr

Ref. A112 Family : 20

Rev. 05

Date : 14 Dec. 2022

Page 1/1

BRONZE SWING CHECK VALVE Ref. A112ØA/A1

SERIES :

- A112ØA : Inlet smooth finish / outlet flanged
- Full bore
- Oblique seat : 15°

For material compatibility, contact us

CHARACTERISTICS :

- PN16 (Nominal Pressure)
- ENDS : Smooth / fixed flange ISO PN16 or loose flange ISO PN10
- MATERIAL : BRONZE CC491K

MAXIMUM CONDITIONS OF USE :

- 16 bar of -15°C to 120°C

APPLICATIONS :

- Water-based fluids
- Steam (8 bar)
- Seawater

OPTIONS :

- Special drilling
- Socket welding
- Coupling Victaulic® ou Straub®

Specific dimensions, contact us

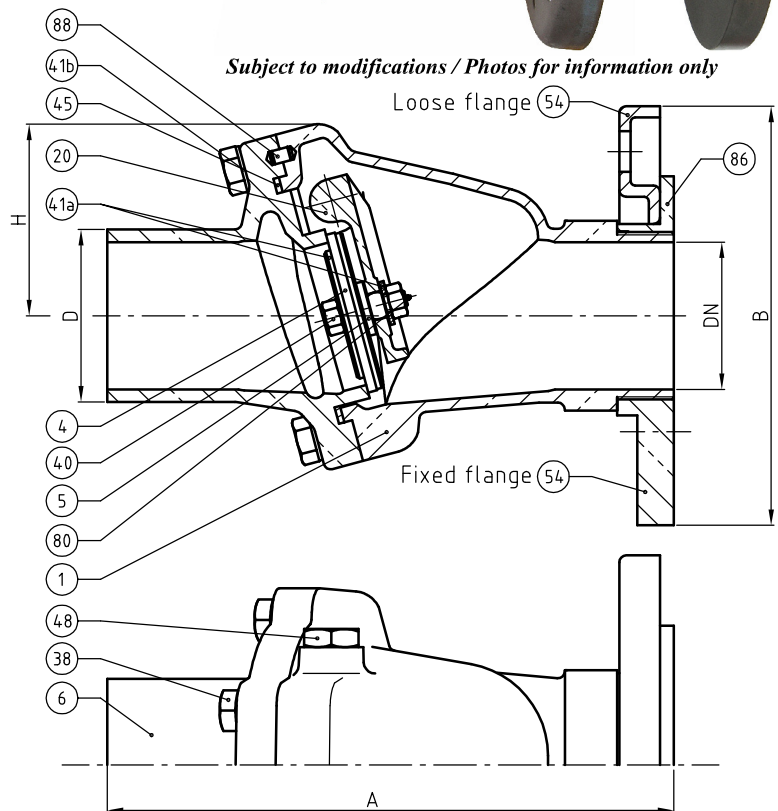

DIMENSIONS						
DN	A (mm)	B (mm)	D (mm) Ref.A112ØA	D (mm) Ref.A112ØA1	H (mm)	n
32	165	140	38	-	67	5
40	180	150	48.3	44.5	72	5
50	208	165	57	-	85	5
65	250	185	76.1	-	85	6
80	270	200	88.9	84	98	7
100	290	220	108	-	111	7
125	353	250	133	-	144	8
150	398	285	159	-	157	8
200	493	340	219	-	173	9

REFERENCES NORMS :

- Material : NF EN 1982 - NF EN 12163 - NF EN 12164 - NF EN 10272
- Testing & checking : NF EN 12266-1/-2 (bench test)
- Flange : NF EN 1092-3

Ref. instruction of assembling : 0904DA139E

Ref. instruction of operation : 0904DA089E

Mounting & assembly guides are available on our website.

NOMENCLATURE			
Rep	Qty	Designation	Material
1	1	BODY	BRONZE
4	1	DISC	FPM
5	1	DISC HOLDER	ALUMINIUM BRONZE
6	1	SEAT	BRONZE
20	1	LEVER	ALUMINIUM BRONZE
38	n	SCREW	STAINLESS STEEL
40	1	NUT	STAINLESS STEEL
41a	1	WASHER	ALUMINIUM BRONZE
41b	n	WASHER	STAINLESS STEEL
45	1	GASKET	FPM
48	1	SLEEVE	ALUMINIUM BRONZE
54	1	FIXED / LOOSE FLANGE	BRONZE / STAINLESS STEEL
80	1	CUSHION	POLYURETHANE
86	1	COLLAR	ALUMINIUM BRONZE
88	1	CENTRING PIN	ALUMINIUM BRONZE

These data are for information and can be modified without notice. It is not up to us to appreciate specifications. It is up to the customer to verify the adequacy between the equipment chosen and the real conditions of use.