



AUTEXIER

MANUFACTURER OF INDUSTRIAL VALVES

93 Rue Louis Blanc - 02300 CHAUNY - FRANCE
 Phone : +33 (0)3 23 52 02 86 Fax : +33 (0)3 23 39 52 28
 Website : www.autexier.fr

Ref. A/AU112 Family : 20

Rev. 02

Date : 19 Dec. 2022

Page 1/1

SUMMARY

SWING CHECK VALVE

Ref. A112.Ø / AU112.Ø

A / A1

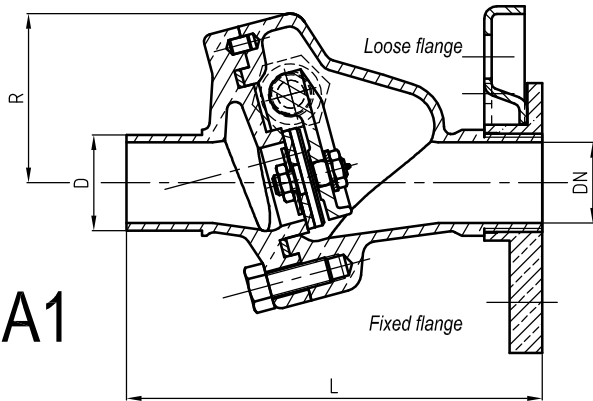

DN	D (mm) Ref. A	D (mm) Ref. A1	L (mm) Std	R (mm)
32	38	x	165	67
40	48.3	44.5	180	71.5
50	57	x	208	76.5
65	76.1	x	250	85
80	88.9	84	270	97.3
100	108	x	290	110.8
125	133	x	353	144
150	159	x	398	156.2
200	219	x	493	173.1

B / B1

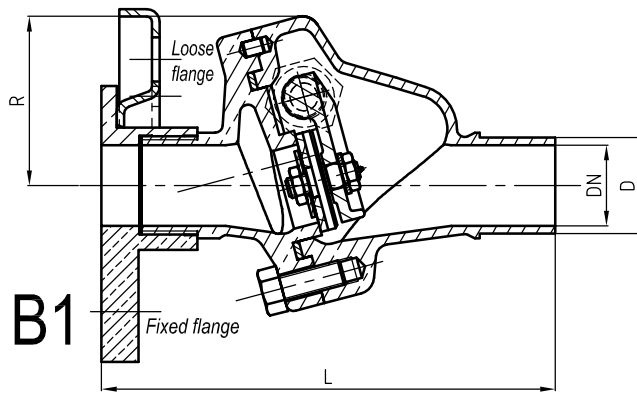

DN	D (mm) Ref. B	D (mm) Ref. B1	L (mm) Std	R (mm)
32	38	x	180	67
40	48.3	44.5	195	71.5
50	57	x	223	76.5
65	76.1	x	265	85
80	88.9	84	295	97.3
100	108	x	305	110.8
125	133	x	370	144
150	159	x	420	156.2
200	219	x	515	173.1

C / C1

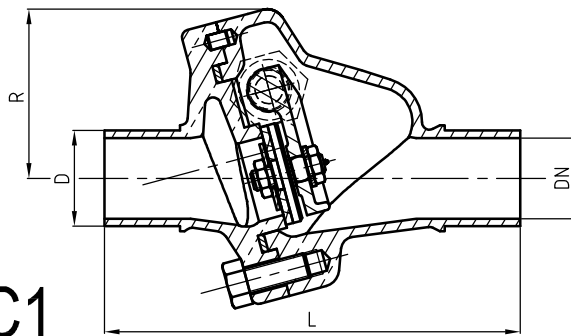

DN	D (mm) Ref. C	D (mm) Ref. C1	L (mm) Std	L (mm) Maxi	L (mm) Brut	R (mm)
32	38	x	165	180	188	67
40	48.3	44.5	180	190	202	71.5
50	57	x	208	210	215	76.5
65	76.1	x	250	-	-	85
80	88.9	84	270	-	-	97.3
100	108	x	290	300	305	110.8
125	133	x	353	-	-	144
150	159	x	398	420	430	156.2
200	219	x	493	-	-	173.1

D / E

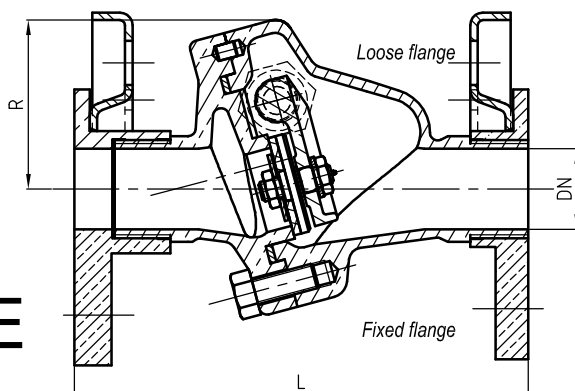

DN	L (mm) Std	L (mm) Mini	R (mm)
32	180	180	67
40	195	190	71.5
50	223	210	76.5
65	265	230	85
80	295	260	97.3
100	305	295	110.8
125	370	360	144
150	420	400	156.2
200	515	465	173.1

These data are for information and can be modified without notice. It is not up to us to appreciate specifications. It is up to the customer to verify the adequacy between the equipment chosen and the real conditions of use.