



AUTEXIER

MANUFACTURER OF INDUSTRIAL VALVES

93 Rue Louis Blanc - 02300 CHAUNY - FRANCE
Phone: +33 (0)3 23 52 02 86 Fax: +33 (0)3 23 39 52 28
Website: www.autexier.fr

Ref. 89 Family : 07

Rev. 11

Date : 12 May 2021

Page 1/1

BRONZE SINGLE WEDGE GATE VALVE

Ref. 89Ø / 89BØ / 89TBØ

SERIES :

- 89
 - Inlet/outlet female threaded
- For material compatibility, contact us*



CHARACTERISTICS :

- PN20 (Nominal Pressure)
- ENDS : 89 and 89TB female GAZ threads / 89B female NPT threads
- MATERIAL : BRONZE CC491K

MAXIMUM CONDITIONS OF USE :

- 20 bar of -45°C to 225°C

APPLICATIONS :

- Water-based fluids
- Steam (8 bar)
- Seawater (89TB)

OPTIONS :

- NPT/API connection
- Socket welding
- Flanges

Specific dimensions, contact us



Subject to modifications

NOMENCLATURE

Rep	Qty	Designation	Material
1	1	BODY	BRONZE
2	1	BONNET	BRONZE
3	1	SINGLE WEDGE DISC	BRONZE
7	1	STEM	BRASS/ALUMINIUM BRONZE (89TB)
8	1	HANDWHEEL	LIGHT ALLOY
10	1	STEM NUT	BRASS/ALUMINIUM BRONZE (89TB)
12	1	PACKING	LATTYGRAF / PTFE
13	1	PACKING GLAND	BRASS/ALUMINIUM BRONZE (89TB)
14	1	PACKING NUT	BRASS/ALUMINIUM BRONZE (89TB)
40	1	NUT	BRASS / STAINLESS STEEL (89TB)

DIMENSIONS

DN	08	12	15	20	25	32	40	50	65	80	100
A (mm)	37	40	44	50	55	62	65	72	97	112	138
B (mm)	60	60	60	60	60	70	70	80	110	110	110
D	1/4"	3/8"	1/2"	3/4"	1"	1"1/4	1"1/2	2"	2"1/2	3"	4"
H (mm)	80	80	86	95	105	125	131	156	190	225	316
Weight (Kg)	0.200	0.250	0.350	0.500	0.650	1.000	1.200	1.650	4.200	6.550	11.700

REFERENCES NORMS :

- Material : NF EN 1982 - NF EN 12163 - NF EN 12164 - NF EN 10272
- Testing & checking : NF EN 12266-1/-2 (bench test)

Ref. instruction of assembling : 0904DA121E

Ref. instruction of operation : 0904DA084E

Mounting & assembly guides are available on our website.

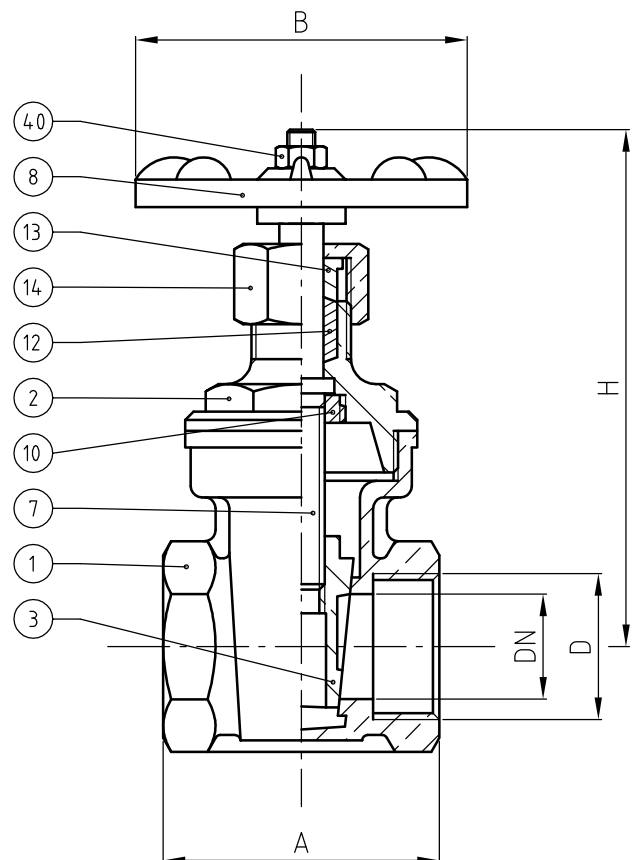

These data are for information and can be modified without notice. It is not up to us to appreciate specifications. It is up to the customer to verify the adequacy between the equipment chosen and the real conditions of use.