



# AUTEXIER

MANUFACTURER OF INDUSTRIAL VALVES

93 Rue Louis Blanc - 02300 CHAUNY - FRANCE  
 Phone : +33 (0)3 23 52 02 86 Fax : +33 (0)3 23 39 52 28  
 Website : www.autexier.fr

Ref. 449 Family : 22

Rev. 06

Date : 15 March 2021

Page 1/1

## BRONZE VISUAL LEVEL CONTROLLER - INFERIOR PART

Ref. 449PIØ

**SERIES :**

- 449PI
- Male threaded
- Contact Stainless steel / Stainless steel
- PI = Inferior Part

*For material compatibility, contact us*

**CARACTERISTICS :**

- PN30 (Nominal Pressure)
- ENDS : GAZ Threads
- MATERIAL : BRONZE CC491K

**MAXIMUM CONDITIONS OF USE :**

- 30 bar of -20°C to 200°C

**APPLICATIONS :**

- Water-based fluids
- Oil & gas
- Steam (13 bar)

**OPTIONS :**

- Tap drain valve (T°<90°C) - Ref. C519.Ø
- Tap drain valve (T°>90°C) - Ref. 255.Ø
- Tube length - 0.2 to 4 meter
- Intermediate connection - Ref. 275
- Pyrex® or rhodoïd tube
- Glass protection
- NPT connection
- Tightness packing special oil & gas
- Extra cost packing  
 (PTFE - Ref.CBT / Graphite - Ref.CBL / Rubber - Ref.CBC / FPM - Ref.CBV)

*Specific dimensions, contact us*

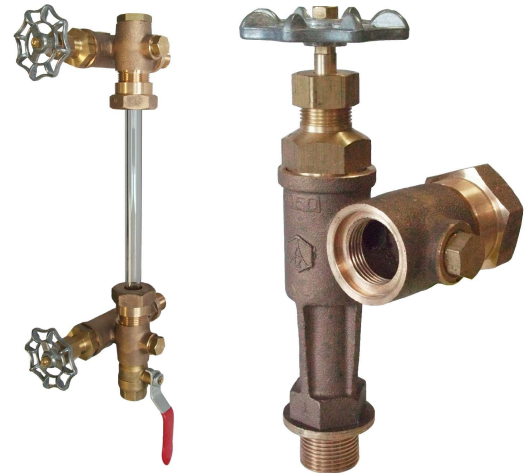

*Subject to modifications*

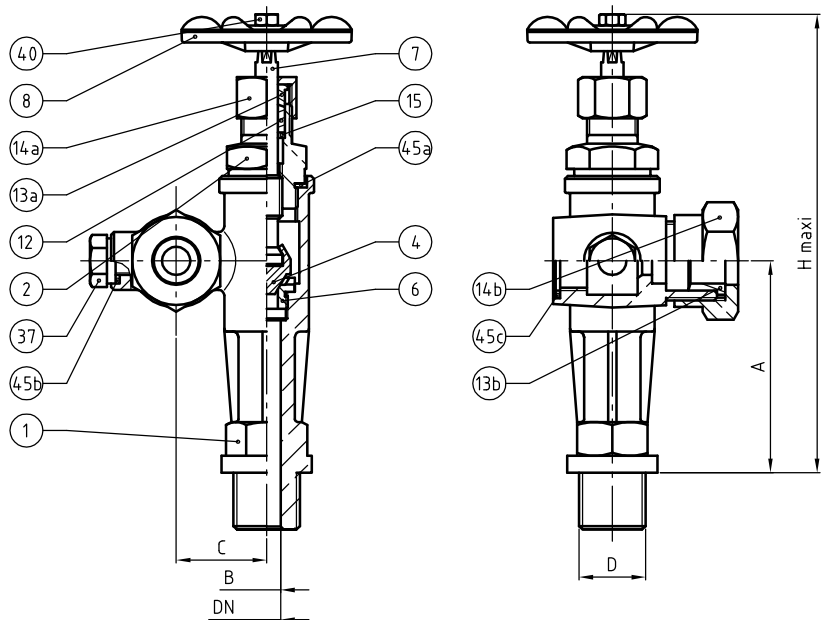

DIMENSIONS		
DN	15	20
A (mm)	75	90
B (mm)	10	15
C (mm)	32	40
D	1/2"	3/4"
H Maxi (mm)	175	195
Weight (Kg)	0.904	1.400

NOMENCLATURE			
Rep	Qty	Designation	Material
1	1	BODY	BRONZE
2	1	BONNET	BRASS
4	1	DISC	STAINLESS STEEL
6	1	SEAT	STAINLESS STEEL
7	1	STEM	BRASS
8	1	HANDWHEEL	LIGHT ALLOY
12	1	PACKING	PTFE
13a	1	PACKING GLAND	BRASS
13b	1	PACKING GLAND	BRASS
14a	1	PACKING NUT	BRASS
14b	1	PACKING NUT	BRONZE
15	1	THRUST DISC	BRASS
37	1	PLUG	BRASS
40	2	NUT	BRASS
45a	1	GASKET	PTFE
45b	1	GASKET	PTFE
45c	1	GASKET	PTFE

**REFERENCES NORMS :**

- Material : NF EN 1982 - NF EN 12163 - NF EN 12164 - NF EN 10272
- Testing & checking : NF EN 12266-1/-2 (bench test)

Ref. instruction of assembling : 0904DA140E

Ref. instruction of operation : 0904DA141E

**Mounting & assembly guides are available on our website.**

*These data are for information and can be modified without notice. It is not up to us to appreciate specifications. It is up to the customer to verify the adequacy between the equipment choosen and the real conditions of use.*