



AUTEXIER

MANUFACTURER OF INDUSTRIAL VALVES

93 Rue Louis Blanc - 02300 CHAUNY - FRANCE
 Phone : +33 (0)3 23 52 02 86 Fax : +33 (0)3 23 39 52 28
 Website : www.autexier.fr

Ref. 150 Family : 22

Rev. 07

Date : 15 March 2021

Page 1/1

BRONZE VISUAL LEVEL CONTROLLER - INFERIOR PART

Ref. 150PIØ

SERIES :

- 150PI
- With flanges
- Contact Bronze / PTFE
- PI = Inferior Part

For material compatibility, contact us

CARACTERISTICS :

- PN30 (Nominal Pressure)
- ENDS : Flange ISO PN 16
- MATERIAL : BRONZE CC491K

MAXIMUM CONDITIONS OF USE :

- 30 bar of -20°C to 200°C

APPLICATIONS :

- Water-based fluids
- Oil & gas
- Steam (13 bar)

OPTIONS :

- Tap drain valve (T°<90°C) - Ref. C519.Ø
- Tap drain valve (T°>90°C) - Ref. 255.Ø
- Tube length - 0.2 to 4 meter
- Intermediate connection - Ref. 350
- Pyrex® or rhodoid tube
- Glass protection
- Tightness packing special oil & gas
- Extra cost packing
(PTFE - Ref.CBT / Graphite - Ref.CBL / Rubber - Ref.CBC / FPM - Ref.CBV)
- Stainless steel ball, allowing automatic closing in case of breakage of the glass tube or the indicator glass (Ref. 250PIØ)

Specific dimensions, contact us

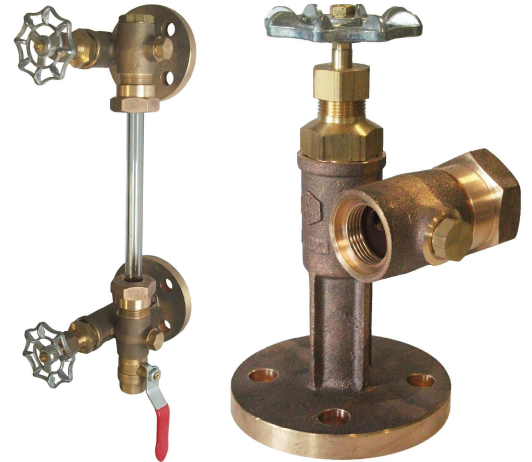

Subject to modifications

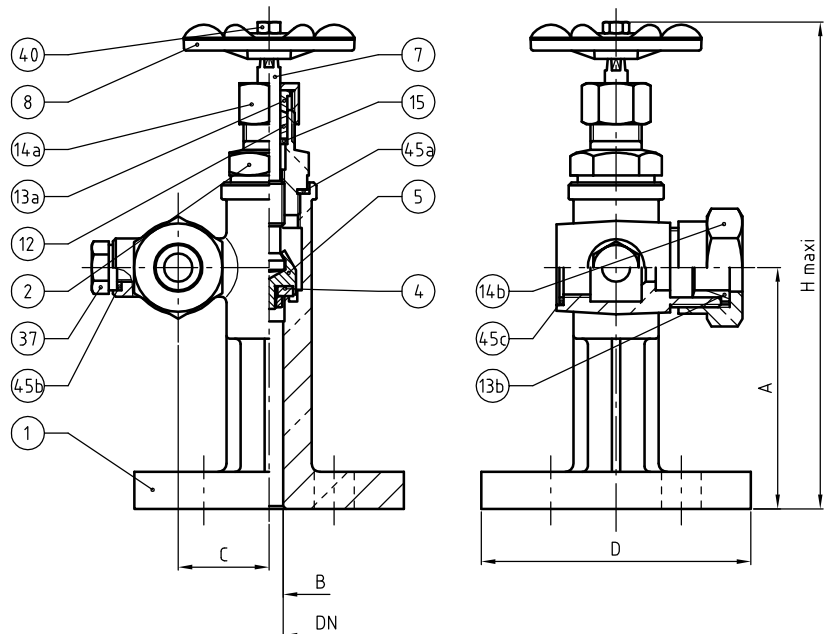

DIMENSIONS		
DN	15	20
A (mm)	85	100
B (mm)	10	15
C (mm)	32	40
D (mm)	95	105
H Maxi (mm)	185	205
Weight (Kg)	1.534	2.133

NOMENCLATURE			
Rep	Qty	Designation	Material
1	1	BODY	BRONZE
2	1	BONNET	BRASS
4	1	DISC	PTFE
5	1	DISC HOLDER	BRASS
7	1	STEM	BRASS
8	1	HANDWHEEL	LIGHT ALLOY
12	1	PACKING	PTFE
13a	1	PACKING GLAND	BRASS
13b	1	PACKING GLAND	BRASS
14a	1	PACKING NUT	BRASS
14b	1	PACKING NUT	BRONZE
15	1	THRUST DISC	BRASS
37	1	PLUG	BRASS
40	2	NUT	BRASS
45a	1	GASKET	PTFE
45b	1	GASKET	PTFE
45c	1	GASKET	PTFE

REFERENCES NORMS :

- Material : NF EN 1982 - NF EN 12163 - NF EN 12164 - NF EN 10272
- Testing & checking : NF EN 12266-1/-2 (bench test)

Ref. instruction of assembling : 0904DA0140E

Ref. instruction of operation : 0904DA141E

Mounting & assembly guides are available on our website.

These data are for information and can be modified without notice. It is not up to us to appreciate specifications. It is up to the customer to verify the adequacy between the equipment chosen and the real conditions of use.