



# AUTEXIER

MANUFACTURER OF INDUSTRIAL VALVES

93 Rue Louis Blanc - 02300 CHAUNY - FRANCE  
 Phone : +33 (0)3 23 52 02 86 Fax : +33 (0)3 23 39 52 28  
 Website : www.autexier.fr

Ref. A1191 Family : 39

Rev. 05

Date : 23 May 2022

Page 1/1

## BRONZE SINGLE WEDGE GATE VALVE

Ref. A1191AØ / A1191AEØ / A1191AØS

### SERIES :

- A1191AØ with travel indicator and two flanges without fitting
  - A1191AEØ with travel indicator and two flanges with a fitting
  - A1191AØS with travel indicator, one flange with a fitting and one flange without fitting
- For material compatibility, contact us

### CARACTERISTICS :

- PN20 (Nominal Pressure)
- ENDS : Flanges PN10/PN16
- MATERIAL : BRONZE CC491K

### MAXIMUM CONDITIONS OF USE :

- 20 bar of -45°C to 225°C

### APPLICATIONS :

- Dielectric transformer

### OPTIONS :

- Special drilling
  - Special flanges
- Specific dimensions, contact us



A1191AØ



A1191AEØ

Subject to modifications

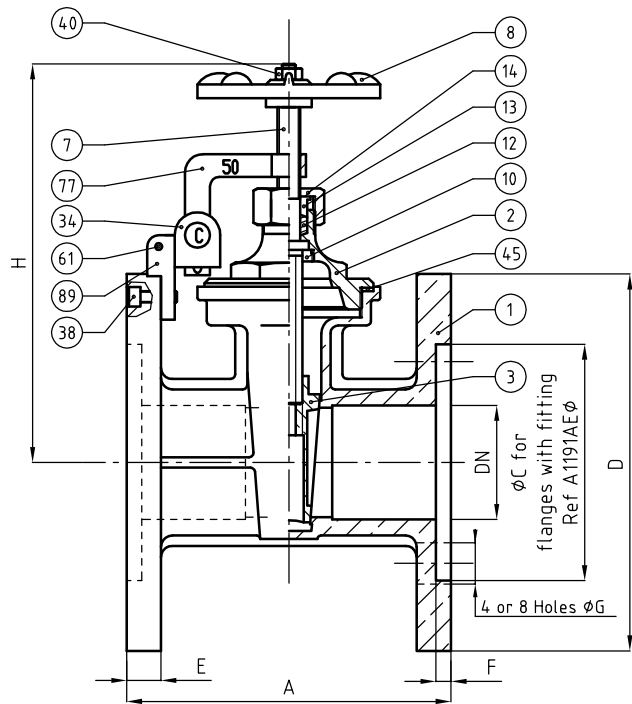

NOMENCLATURE			
Rep	Qty	Designation	Material
1	1	BODY	BRONZE
2	1	BONNET	BRONZE
3	1	SINGLE WEDGE DISC	BRONZE
7	1	STEM	BRASS
8	1	HANDWHEEL	LIGHT ALLOY
10	1	STEM NUT	BRASS
12	1	PACKING	FIBER + GRAPHITE / PTFE
13	1	PACKING GLAND	BRASS
14	1	PACKING NUT	BRASS
38	1	SCREW CHC	STAINLESS STEEL
40	1	NUT H	BRASS
45	1	GASKET	PTFE
61	1	ELASTIC PIN	STAINLESS STEEL
85	1	BOLT	BRONZE
77	1	TRAVEL INDICATOR	BRONZE
89	1	BRACKET	BRONZE

### DIMENSIONS

DN		25	40	50	80	100
A (mm)	80	100	120	142	160	172
C (mm)	50	69	88	103	136	160
D (mm)	95	115	150	165	200	220
E (mm)	9	10	14	15	17	19
F (mm)	4.5	4.5	4.5	4.5	4.5	4.5
G (mm)	14	14	18	18	18	18
H (mm)	105	122	148	175	264	318
Handwheel maxi. tightening torque (N.m)	7 to 10	10 to 14	14 to 18	18 to 22	25 to 30	25 to 30
Weight (Kg) Ref A1191AØ	--	2.426	5.130	6.885	14.440	21.540

### REFERENCES NORMS :

- Material : NF EN 1982 - NF EN 12163 - NF EN 12164 - NF EN 10272
- Testing & checking : NF EN 12266-1/-2 (bench test) - NF C52-123
- Face to face : NF EN 558 - Series 18 (DN15 to DN40)
- Face to face : NF EN 558 - Series 29 (DN50 to DN100)
- Flanges : NF EN 1092-3

Ref. instruction of assembling : 0904DA121E

Ref. instruction of operation : 0904DA084E

**Mounting & assembly guides are available on our website.**

*These data are for information and can be modified without notice. It is not up to us to appreciate specifications. It is up to the customer to verify the adequacy between the equipment chosen and the real conditions of use.*