



AUTEXIER

MANUFACTURER OF INDUSTRIAL VALVES

93 Rue Louis Blanc - 02300 CHAUNY - FRANCE
 Phone : +33 (0)3 23 52 02 86 Fax : +33 (0)3 23 39 52 28
 Website : www.autexier.fr

Ref. AU302 Family : 13

Rev. 01

Date : 28 April 2022

Page 1/3

ALUMINIUM BRONZE ANGLE GLOBE VALVE WITH FLANGES

Ref. AU302CØ / AU302JØ / AU302TØ

SERIES :

- AU302C : Contact Bronze / Bronze
- AU302J : Contact Bronze / Jenkins
- AU302T : Contact Bronze / PTFE
- Outside rising stem

For material compatibility, contact us

CHARACTERISTICS :

- PN20 (Nominal Pressure)
- ENDS : ISO Flanges PN16
- MATERIAL : ALUMINIUM BRONZE CC333G

MAXIMUM CONDITIONS OF USE :

- AU302C15 : 20 bar of -10°C to 225°C / AU302CØ : 20 bar of -10°C to 200°C
- AU302J15 : 20 bar of -10°C to 200°C / AU302JØ : 20 bar of -10°C to 200°C
- AU302T15 : 20 bar of -10°C to 225°C / AU302TØ : 20 bar of -10°C to 200°C

APPLICATIONS :

- Water-based fluids
- Steam (16 bar)
- Non toxic gases
- Water

OPTIONS :

- Special drilling
- Specific dimensions, contact us

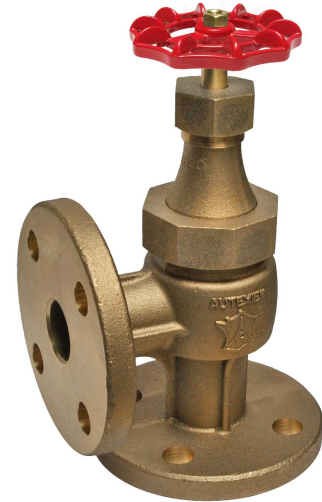

Subject to modifications

NOMENCLATURE			
Rep	Qty	Designation	Material
1	1	BODY	ALUMINIUM BRONZE
2	1	BONNET	ALUMINIUM BRONZE
4	1	DISC	ALU. BRONZE / JENKINS / PTFE
5	1	DISC HOLDER	ALUMINIUM BRONZE
7	1	STEM	ALUMINIUM BRONZE
8	1	HANDWHEEL	LIGHT ALLOY
9	1	BONNET NUT	ALUMINIUM BRONZE
12	1	PACKING	FIBER+GRAPHITE
14	1	PACKING NUT	ALUMINIUM BRONZE
15	1	THRUST DISC	ALUMINIUM BRONZE
40a	1	NUT	STAINLESS STEEL
40b	1	NUT	STAINLESS STEEL
41	1	WASHER	STAINLESS STEEL
45	1	O-RING (EXCEPT DN15)	FPM

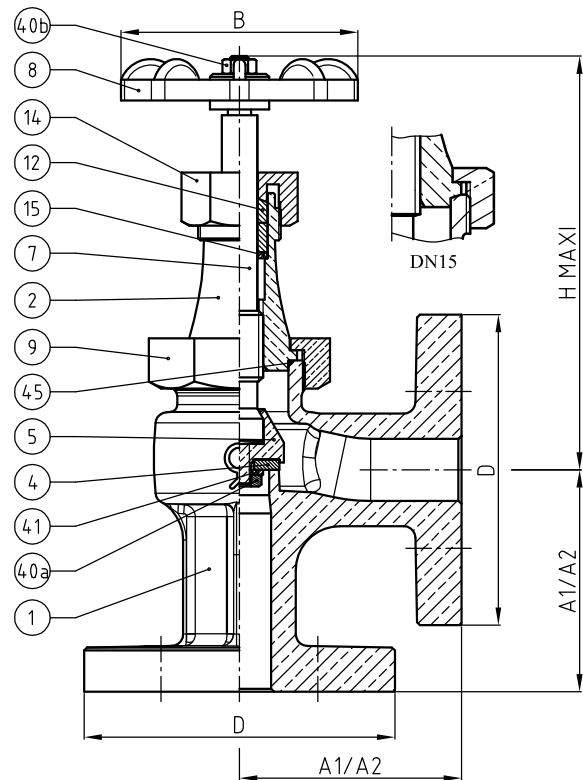

REFERENCES NORMS :

- Material : NF EN 1982 - NF EN 12163 - NF EN 12164 - NF EN 10272
- Testing & checking : NF EN 12266-1/-2 (bench test)
- Face to axis : NF EN 558 - Series 22 (A1) or Series 23 (A2)
- Flanges : NF EN 1092-3

Ref. instruction of assembling : 0904DA124E

Ref. instruction of operation : 0904DA088E

Mounting & assembly guides are available on our website.

DIMENSIONS							
DN	15	20	25	32	40	50	65
A1 (mm)	65	70	80	90	95	105	115
A2 (mm)	70	75	85	95	100	115	125
B (mm)	70	80	90	90	110	110	110
D (mm)	95	105	115	140	150	165	185
H (mm)	120	155	170	190	215	250	250
Weight (Kg)	--	3.110	--	6.360	--	--	--

These data are for information and can be modified without notice. It is not up to us to appreciate specifications. It is up to the customer to verify the adequacy between the equipment chosen and the real conditions of use.



AUTEXIER

MANUFACTURER OF INDUSTRIAL VALVES

93 Rue Louis Blanc - 02300 CHAUNY - FRANCE
 Phone : +33 (0)3 23 52 02 86 Fax : +33 (0)3 23 39 52 28
 Website : www.autexier.fr

Ref. AU302 Family : 13

Rev. 01

Date : 28 April 2022

Page 2/3

ALUMINIUM BRONZE ANGLE GLOBE VALVE WITH FLANGES

Ref. AU302CØ / AU302JØ / AU302TØ

SERIES :

- AU302C : Contact Bronze / Bronze
- AU302J : Contact Bronze / Jenkins
- AU302T : Contact Bronze / PTFE
- Outside rising stem

For material compatibility, contact us



CARACTERISTICS :

- PN30 (Nominal Pressure)
- ENDS : ISO Flanges PN16
- MATERIAL : ALUMINIUM BRONZE CC333G

MAXIMUM CONDITIONS OF USE :

- 30 bar of -10°C to 200°C

APPLICATIONS :

- Water-based fluids
- Steam (16 bar)
- Non toxic gases
- Water

OPTIONS :

- Special drilling
- Specific dimensions, contact us*

Subject to modifications

NOMENCLATURE			
Rep	Qty	Designation	Material
1	1	BODY	ALUMINIUM BRONZE
2	1	BONNET	ALUMINIUM BRONZE
4	1	DISC	ALU. BRONZE / JENKINS / PTFE
5	1	DISC HOLDER	ALUMINIUM BRONZE
7	1	STEM	ALUMINIUM BRONZE
8	1	HANDWHEEL	LIGHT ALLOY
12	4	PACKING	FIBER+GRAPHITE
13	1	PACKING GLAND	ALUMINIUM BRONZE
17	1	PACKING FLANGE	ALUMINIUM BRONZE
38a	2	SCREW	STAINLESS STEEL
38b	8	SCREW	STAINLESS STEEL
40a	1	NUT	STAINLESS STEEL
40b	1	NUT	STAINLESS STEEL
41a	1	WASHER	STAINLESS STEEL
41b	1	WASHER	STAINLESS STEEL
41c	1	WASHER	STAINLESS STEEL
41d	1	WASHER	STAINLESS STEEL
45	1	O-RING	FPM

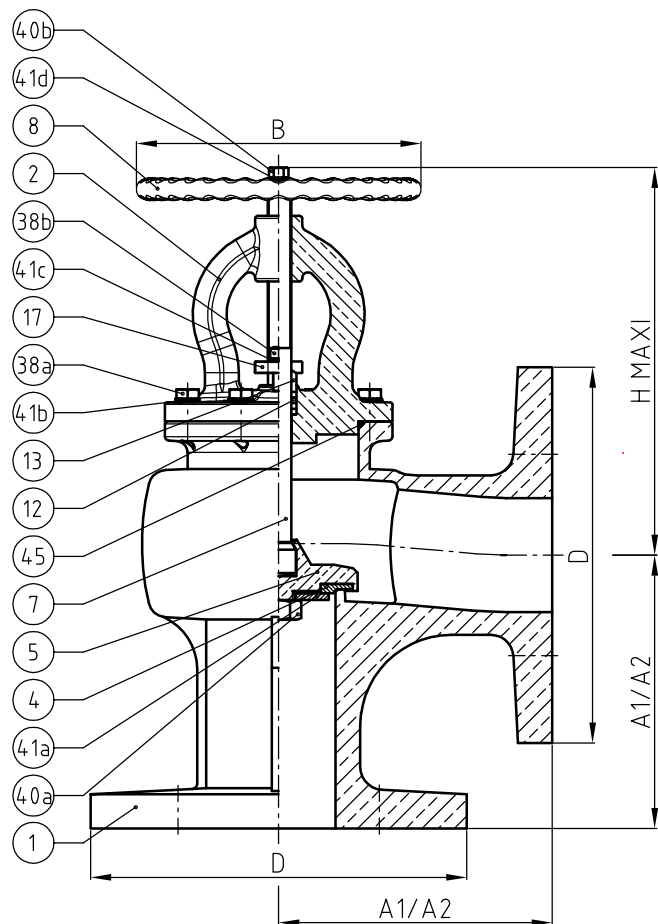

REFERENCES NORMS :

- Material : NF EN 1982 - NF EN 12163 - NF EN 12164 - NF EN 10272
- Testing & checking : NF EN 12266-1/-2 (bench test)
- Face to axis : NF EN 558 - Series 22 (A1) or Series 23 (A2)
- Flanges : NF EN 1092-3

Ref. instruction of assembling : 0904DA124E

Ref. instruction of operation : 0904DA088E

Mounting & assembly guides are available on our website.

DIMENSIONS		
DN	80	100
A1 (mm)	125	135
A2 (mm)	135	146
B (mm)	110	150
D (mm)	200	220
H (mm)	355	400*
Weight (Kg)	--	--

**Under reserve*

These data are for information and can be modified without notice. It is not up to us to appreciate specifications. It is up to the customer to verify the adequacy between the equipment chosen and the real conditions of use.



AUTEXIER

MANUFACTURER OF INDUSTRIAL VALVES

93 Rue Louis Blanc - 02300 CHAUNY - FRANCE
 Phone : +33 (0)3 23 52 02 86 Fax : +33 (0)3 23 39 52 28
 Website : www.autexier.fr

Ref. AU302 Family : 13

Rev. 01

Date : 28 April 2022

Page 3/3

ALUMINIUM BRONZE ANGLE GLOBE VALVE WITH FLANGES

Ref. AU302CØ / AU302JØ / AU302TØ

SERIES :

- AU302C : Contact Bronze / Bronze
- AU302J : Contact Bronze / Jenkins
- AU302T : Contact Bronze / PTFE
- Outside rising stem

For material compatibility, contact us



CARACTERISTICS :

- PN30 (Nominal Pressure)
- ENDS : ISO Flanges PN16
- MATERIAL : ALUMINIUM BRONZE CC333G

MAXIMUM CONDITIONS OF USE :

- 30 bar of -10°C to 200°C

APPLICATIONS :

- Water-based fluids
- Steam (16 bar)
- Non toxic gases
- Water

OPTIONS :

- Special drilling
- Specific dimensions, contact us*

Subject to modifications

NOMENCLATURE			
Rep	Qty	Designation	Material
1	1	BODY	ALUMINIUM BRONZE
2	1	BONNET	ALUMINIUM BRONZE
4	1	DISC	ALU. BRONZE / JENKINS / PTFE
5	1	DISC HOLDER	ALUMINIUM BRONZE
7	1	STEM	ALUMINIUM BRONZE
8	1	HANDWHEEL	LIGHT ALLOY
12	4	PACKING	FIBER+GRAPHITE
13	1	PACKING GLAND	ALUMINIUM BRONZE
17	1	PACKING FLANGE	ALUMINIUM BRONZE
38a	2	SCREW	STAINLESS STEEL
38b	8	SCREW	STAINLESS STEEL
40a	1	NUT	STAINLESS STEEL
40b	1	NUT	STAINLESS STEEL
41a	1	WASHER	STAINLESS STEEL
41b	1	WASHER	STAINLESS STEEL
41c	1	WASHER	STAINLESS STEEL
41d	1	WASHER	STAINLESS STEEL
45	1	O-RING	FPM

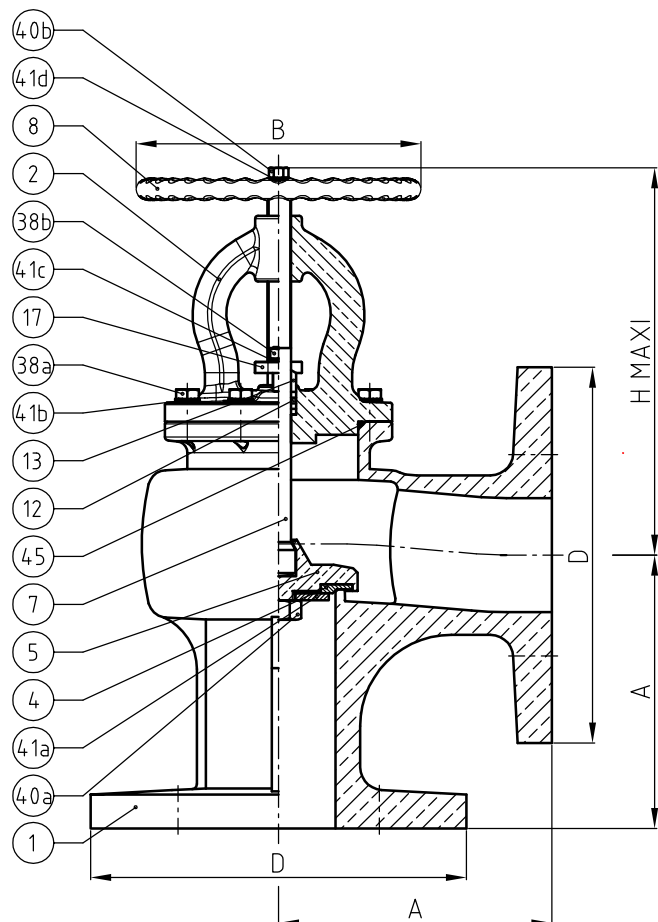

REFERENCES NORMS :

- Material : NF EN 1982 - NF EN 12163 - NF EN 12164 - NF EN 10272
- Testing & checking : NF EN 12266-1/-2 (bench test)
- Face to axis : NF EN 558 - Series 08
- Flanges : NF EN 1092-3

Ref. instruction of assembling : 0904DA124E

Ref. instruction of operation : 0904DA088E

Mounting & assembly guides are available on our website.

DIMENSIONS		
DN	125	150
A (mm)	200	225
B (mm)	150	150
D (mm)	250	285
H (mm)	450*	500
Weight (Kg)	--	--

**Under reserve*

These data are for information and can be modified without notice. It is not up to us to appreciate specifications. It is up to the customer to verify the adequacy between the equipment chosen and the real conditions of use.