



# AUTEXIER

MANUFACTURER OF INDUSTRIAL VALVES

93 Rue Louis Blanc - 02300 CHAUNY - FRANCE  
Phone : +33 (0)3 23 52 02 86 Fax : +33 (0)3 23 39 52 28  
Website : www.autexier.fr

Ref. 154 Family : 30

Rev. 09

Date : 07 Oct. 2021

Page 1/1

## EXPANSION BEND Ref. 154.Ø

### SERIES :

- 154
  - Double tightness O-ring
- For material compatibility, contact us



### CHARACTERISTICS :

- PN16 (Nominal Pressure)
- ENDS : GAZ Threads
- MATERIAL : BRONZE CC491K

### MAXIMUM CONDITIONS OF USE :

- 16 bar of -15°C to 180°C

### APPLICATIONS :

- Over-heated water
- Steam (13 bar)
- Oil & gas, paintings, adhesives

### OPTIONS :

- NPT Threads
- Flanges connection
- **NEVER DO PAINTING ON EXPANSION BEND**

Specific dimensions, contact us



Subject to modifications

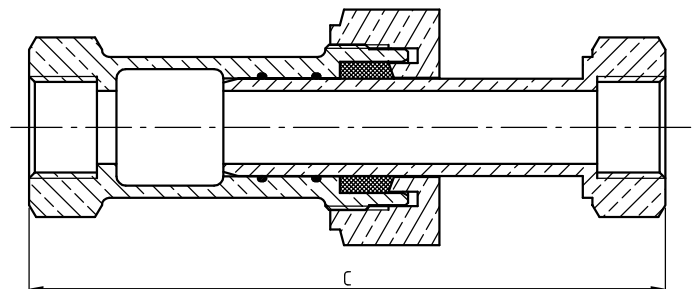
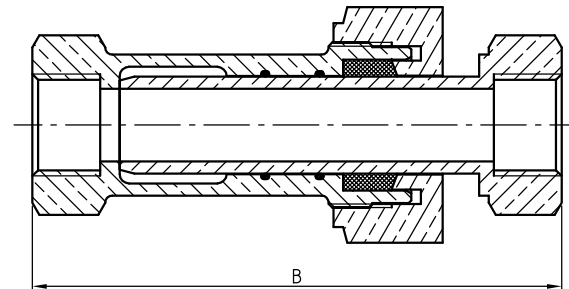
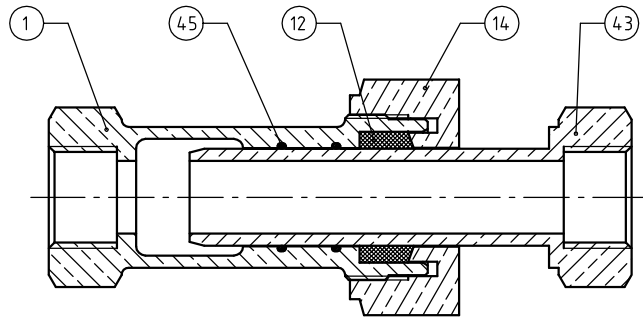

### DIMENSIONS

DN	12	15	20	25	32	40	50	65	80
A (mm)	119	120	129	143	167	174	190	206	231
B (mm)	109	109	118	132	152	158	170	185	206
C (mm)	129	131	140	154	182	190	210	227	256
O	3/8	1/2	3/4	1"	1 1/4"	1 1/2"	2"	1 1/2"	2"
P (mm)	14	14	15	18	19	20	22	25	27
Axial Movement (mm)	±10	±11	±11	±11	±15	±16	±20	±21	±25
Weight (Kg)	0.450	0.565	0.820	1.212	1.858	2.530	3.360	4.940	7.600

### NOMENCLATURE

Rep	Qty	Designation	Material
1	1	BODY	BRONZE
12	1	PACKING	GRAPHITE CERAMIC
14	1	PACKING NUT	BRONZE
43	1	TUBE	BRONZE
45	2	O-RING	FPM

### REFERENCES NORMS :

- Material : NF EN 1982 - NF EN 12163 - NF EN 12164 - NF EN 10272
- Testing & checking : NF EN 12266-1/-2 (bench test)

Ref. instruction of assembling : 0904DA111E

Ref. instruction of operation : 0904DA112E

**Mounting & assembly guides are available on our website.**

These data are for information and can be modified without notice. It is not up to us to appreciate specifications. It is up to the customer to verify the adequacy between the equipment chosen and the real conditions of use.