



AUTEXIER

MANUFACTURER OF INDUSTRIAL VALVES

93 Rue Louis Blanc - 02300 CHAUNY - FRANCE
 Phone : +33 (0)3 23 52 02 86 Fax : +33 (0)3 23 39 52 28
 Website : www.autexier.fr

Ref. 111 Family : 20

Rev. 03

Date : 21 April 2021

Page 1/1

BRONZE WAFER SWING CHECK VALVE Ref. 111.Ø

SERIES :

- 111.Ø
- Between flanges
- DN ≥ 100 lifting ring

For material compatibility, contact us

CARACTERISTICS :

- PN30 (Nominal Pressure)
- ENDS : For ISO PN10/16 Flanges
- MATERIAL : BRONZE CC491K

MAXIMUM CONDITIONS OF USE :

- 30 bar of -15°C to 200°C

APPLICATIONS :

- Water-based fluids
- Steam (8 bar)

OPTIONS :

- DN < 100 lifting ring
- For ASA 150 Flanges

Specific dimensions, contact us



Subject to modifications

NOMENCLATURE			
Rep	Qty	Designation	Material
1	1	BODY	BRONZE
4	1	DISC	FPM
5	1	DISC HOLDER	BRONZE
23	1	SPRING	STAINLESS STEEL
40	1	NUT	STAINLESS STEEL
41	1	WASHER	BRONZE
45	1	O-RING	FPM
48	1	SLEEVE	BRONZE

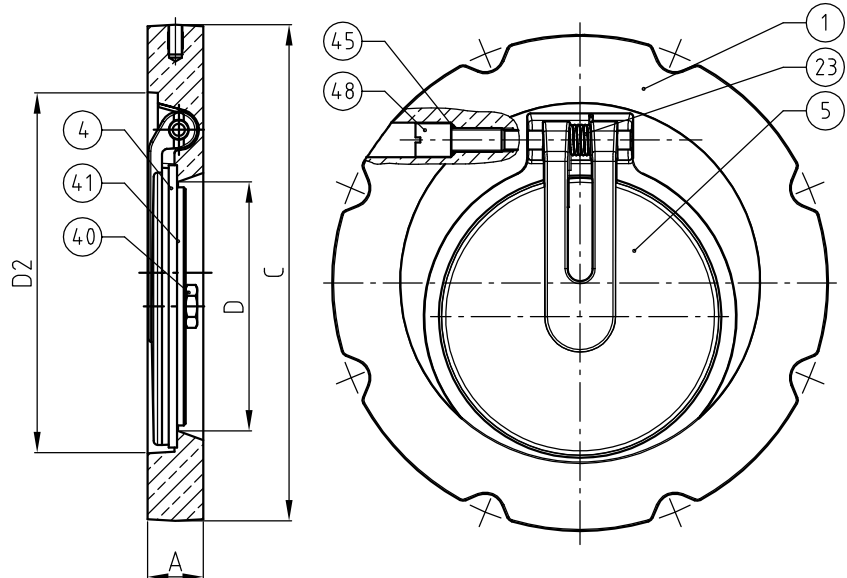

REFERENCES NORMS :

- Material : NF EN 1982 - NF EN 12163 - NF EN 12164 - NF EN 10272
- Testing & checking : NF EN 12266-1/-2 (bench test)
- Face to face: NF E 29-377 - Series ISO PN 50

Ref. instruction of assembling : 0904DA164E

Ref. instruction of operation : 0904DA163E

Mounting & assembly guides are available on our website.

DIMENSIONS										
DN	40	50	65	80	100	125	150	200	250	300
A (mm)	22	22	22	22	24	26	26	33	52	58
C (mm)	110	125	145	160	180	210	240	295	355	410
D (mm)	20	27	41	50	65	88	110	148	193	249
D2 (mm)	43	54	70	86	107	134	160	214	268	321

These data are for information and can be modified without notice. It is not up to us to appreciate specifications. It is up to the customer to verify the adequacy between the equipment chosen and the real conditions of use.