



AUTEXIER

MANUFACTURER OF INDUSTRIAL VALVES

93 Rue Louis Blanc - 02300 CHAUNY - FRANCE
 Phone: +33 (0)3 23 52 02 86 Fax: +33 (0)3 23 39 52 28
 Website: www.autexier.fr

Ref.: AU591 Family: 09

Rev.: 00

Date: 17 Sept. 2019

Page 1/1

ALUMINIUM-BRONZE DOUBLE WEDGE GATE VALVE WITH FLANGES

Ref: AU594.51

SERIES :

- AU594

For material compatibility, contact us

CARACTERISTICS :

- PN16 (Nominal Pressure)
- ENDS : Flanges ISO PN10 or PN16
- MATERIAL : ALUMINIUM-BRONZE CC333G

MAXIMUM CONDITIONS OF USE :

- 16 bar of -15°C to 200°C

APPLICATIONS :

- Seawater
- Water-based fluids
- Steam (8 bar)

OPTIONS :

- Special drilling
- Face to face

Specific dimensions, contact us

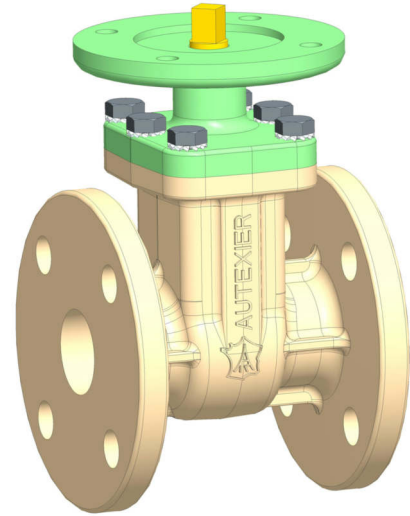

Subject to modifications

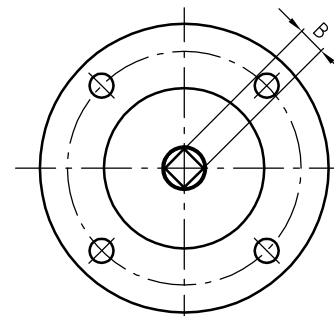
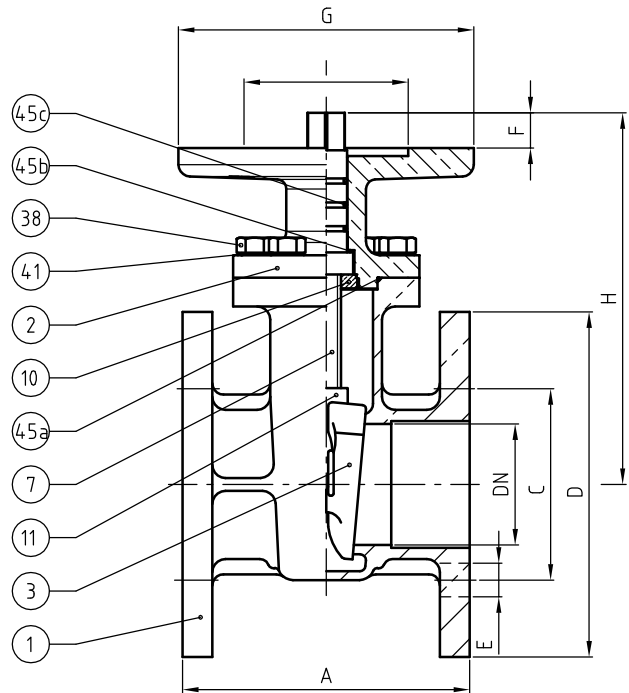

NOMENCLATURE

Rep	Qty	Designation	Material
1	1	BODY	ALUMINIUM-BRONZE
2	1	BONNET	ALUMINIUM-BRONZE
3	1	DOUBLE WEDGE DISC	ALUMINIUM-BRONZE
7	1	STEM	ALUMINIUM-BRONZE
10	1	STEM NUT	ALUMINIUM-BRONZE
11	1	WEDGE DISC NUT	ALUMINIUM-BRONZE
38	6	SCREW	STAINLESS STEEL
41	6	WASHER	STAINLESS STEEL
45a	1	O-RING	FPM
45b	1	GASKET	PTFE
45c	3	O-RING	FPM

DIMENSIONS

DN	A (mm)	B (mm)	C (mm)	D (mm)	E (mm)	F (mm)	G (mm)	H (mm)	I (mm)
50	142	12	125	165	18	15.5	125	168	70

REFERENCES NORMS :

- Material: NF EN 1982 - NF EN 12164 - NF EN 10272
- Testing & checking: NF EN 12266-1/-2 (bench test)
- Face to face: NF EN 558 - Series 29

Ref. instruction of assembling: 0904DA123E

Ref. instruction of operation: 0904DA087E

Mounting & assembly guides are available on our website.

These data are for information and can be modified without notice. It is not up to us to appreciate specifications. It is up to the customer to verify the adequacy between the equipment chosen and the real conditions of use.