



# AUTEXIER

MANUFACTURER OF INDUSTRIAL VALVES

93 Rue Louis Blanc - 02300 CHAUNY - FRANCE  
 Phone: +33 (0)3 23 52 02 86 Fax: +33 (0)3 23 39 52 28  
 Website: www.autexier.fr

Ref.: AU593 Family: 09

Rev.: 02

Date: 30 Jan. 2018

Page 1/1

## ALUMINIUM-BRONZE DOUBLE WEDGE GATE VALVE WITH FLANGES

Ref: AU593.ØMN

**SERIES :**

- AU593
  - Outside rising stem
  - Construction in accordance with MN 7063 HD
- For material compatibility, contact us*

**CARACTERISTICS :**

- PN30 (Nominal Pressure)
- ENDS : Flanges MN 7068 E
- MATERIAL : ALUMINIUM-BRONZE CC332G

**MAXIMUM CONDITIONS OF USE :**

- 30 bar of -15°C to 200°C

**APPLICATIONS :**

- Seawater
- Water-based fluids
- Steam (8 bar)

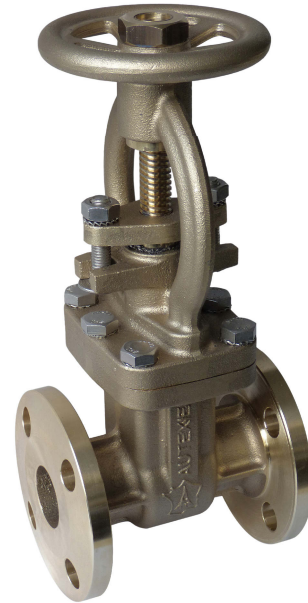

*Subject to modifications*

NOMENCLATURE			
Rep	Qty	Designation	Material
1	1	BODY	ALUMINIUM-BRONZE
2	1	BONNET	ALUMINIUM-BRONZE
3	1	DOUBLE WEDGE DISC	ALUMINIUM-BRONZE
7	1	STEM	ALUMINIUM-BRONZE
8	1	HANDWHEEL	ALUMINIUM-BRONZE
10	1	STEM NUT	ALUMINIUM-BRONZE
11	1	WEDGE DISC NUT	ALUMINIUM-BRONZE
12	m	PACKING	PTFE
17	1	PACKING GLAND FLANGE	ALUMINIUM-BRONZE
38a	n	SCREW	STAINLESS STEEL
38b	2	SCREW	STAINLESS STEEL
40a	2	NUT	STAINLESS STEEL
40b	1	NUT	ALUMINIUM-BRONZE
41	o	WASHER	STAINLESS STEEL
45	1	O-RING	FPM
61	1	PIN	STAINLESS STEEL

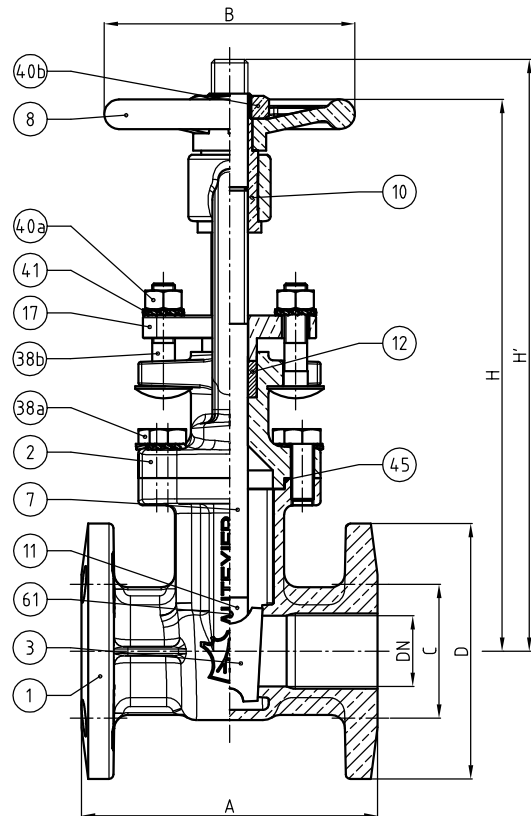

DIMENSIONS										
DN	A (mm)	B (mm)	C (mm)	D (mm)	H (mm)	H' (mm)	m	n	o	Weight (kg)
32	130	110	83	112	245	255	1	6	8	7.490
80	160	175	139	168	368	460	3	8	13	21.250

**REFERENCES NORMS :**

- Material: NF EN 1982 - NF EN 12164 - NF EN 10272
- Testing & checking: NF EN 12266-1/-2 (bench test)
- Face to face: NF EN 558 - Series 29 (DN80)
- Face to face: MN 7063-HD (DN32)

Ref. instruction of assembling: 0904DA165E

Ref. instruction of operation: 0904DA166E

**Mounting & assembly guides are available on our website.**

*These data are for information and can be modified without notice. It is not up to us to appreciate specifications. It is up to the customer to verify the adequacy between the equipment chosen and the real conditions of use.*