



AUTEXIER

**MANUFACTURER OF INDUSTRIAL MARINE AND OIL & GAS VALVES
IN BRONZE AND ALUMINIUM-BRONZE**

93, rue Louis Blanc - 02300 CHAUNY - FRANCE
Tel : +33 (0)3.23.52.02.86 - Fax : +33 (0)3.23.39.52.28
www.autexier.fr

Instruction for use

Conventional safety valve 181 / AU181 / 281 / AU281 / 381 / AU381 / 481 / AU481

Operation

If the inlet pressure is less than the opening pressure: the *spring 23* plates *disc 4* on *seat 6* via *disc holder 5* of *needle 27* and *support 25*. The valve does not start, it remains closed. The pressure at the inlet orifice is higher than or equal to the pressure of beginning of opening, (appreciably with the pressure of taring), the fluid exerts an ascending push on *disc 4* allowing its lifting of *seat 6*. This movement is allowed thanks to the *disc holder 5* which slides in the *lantern 22*. This lifting will be carried out until the pressure of opening is reached (maximum pressure in the valve) for which the flow is nominal.

When the pressure falls upstream of the valve, *disc 4* gradually occults the passage until coming to block the flow (contact with *seat 6* when the pressure upstream is equal to the pressure of closing).

Taring

Taring is the operation which consists with pre forcing the mechanism of the valve so that its opening occurs with a called pressure pre given pressure of taring (corresponding to the pressure of opening). This operation consists in forcing the *spring 23* using the *support 25* and *adjusting screw 24*. Effort thus produced plate *disc 4* by the means of *disc holder 5*, *needle 27* and *support 25*. To avoid any drift in the time of this taring, the adjustment is blocked with *nut 40*. To prevent any intervention of the user on this adjustment, the whole is protected by leading between the *adjusting screw 24* and the *lantern 22* to certify the integrity of taring throughout the life of the valve.

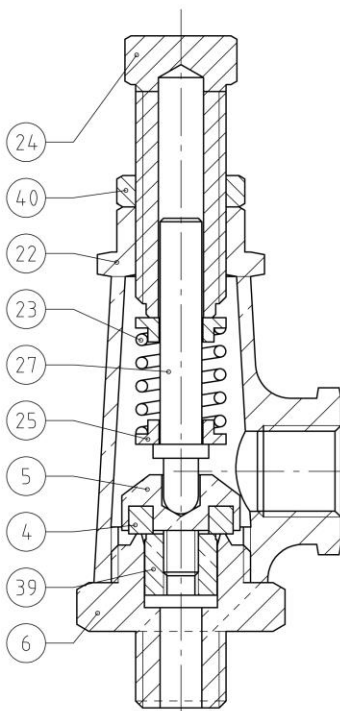

281 / AU281: DN08 to 15 & 80
381.80 / AU381.80 / 381S80 / AU381S80

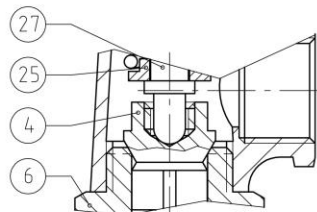

181 / AU181.Ø

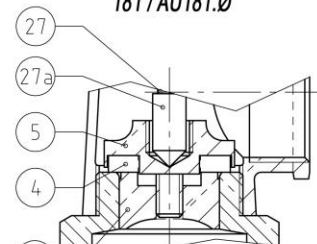

281 / AU281: DN20 to 65
381 / AU381 / 381S / AU381S: DN32 to 65

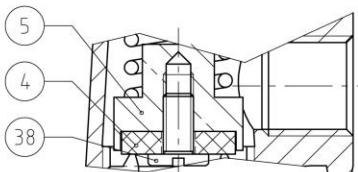

381 / AU381 / 381S / AU381S: DN08 to 25



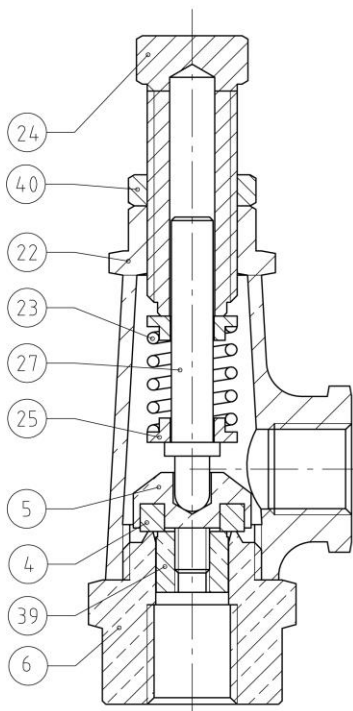

481T / AU481T: DN08 to 15 & 80
 481.80 / AU481.80 / 481S80 / AU481S80

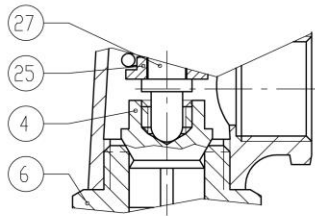

481MØ / AU481MØ

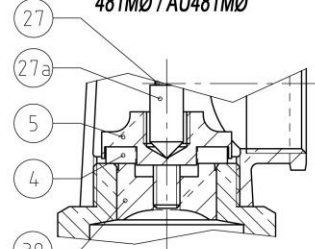

481T / AU481T: DN20 to 65
 481 / AU481 / 481S / AU481S: DN32 to 65

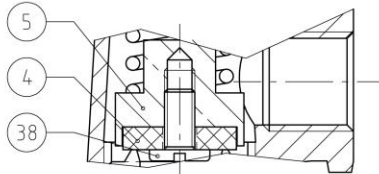

481 / AU481 / 481S / AU481S: DN08 to 25



Ref. Document 0904DA155E version 02 of 11 March 2015

